

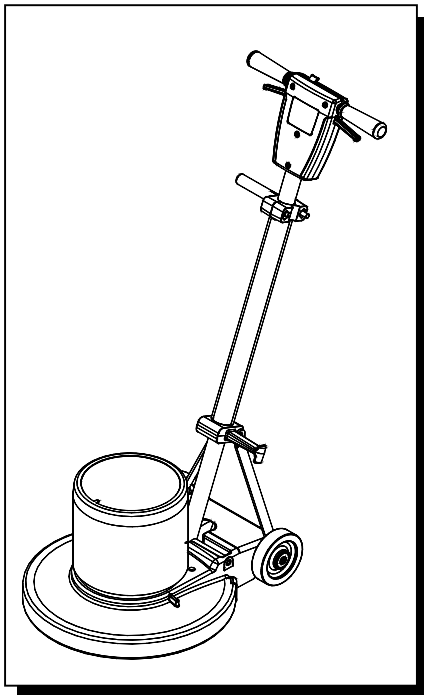

Operating Instructions (ENG)

FLOOR POLISHER



MODELS:	SP13 10090220	SP17X 10090280
	SP15 10090230	SP20X 10090320
	SP17 10090240	SPDS20 10090350
	SP20 10090310	

QUEST® . . . for Continuous Improvement.
Windsor's Quality Management System is Certified ISO 9001.



Read these instructions before using the machine.

G

86221940 12/29/06

PRV NO. 980100

MACHINE DATA LOG/OVERVIEW

MODEL _____

DATE OF PURCHASE _____

SERIAL NUMBER _____

YOUR DEALER

Name: _____

Address: _____

Phone Number: _____

TABLE OF CONTENTS

<i>Machine Data Log/Overview.....</i>	<i>2</i>
<i>Table of Contents.....</i>	<i>3</i>

HOW TO USE THIS MANUAL

<i>How to use this Manual.....</i>	<i>4</i>
------------------------------------	----------

SAFETY

<i>Important Safety Instructions</i>	<i>1-1</i>
<i>Hazard Intensity Level.</i>	<i>1-2</i>
<i>Grounding Instructions.....</i>	<i>1-3</i>

OPERATION / MAINTENANCE

<i>Technical Specifications</i>	<i>2-1</i>
<i>Handle Installation</i>	<i>2-2</i>
<i>Operation</i>	<i>2-3</i>
<i>Pad Driver Installation.....</i>	<i>2-4</i>
<i>Maintenance</i>	<i>2-5</i>
<i>Service Schedule.....</i>	<i>2-5</i>
<i>Machine Troubleshooting.....</i>	<i>2-6</i>

GROUP PARTS LIST

<i>Brush/Pad Driver Group.....</i>	<i>3-1</i>
<i>Frame Group.....</i>	<i>3-3</i>
<i>Motor Group.....</i>	<i>3-5</i>
<i>Handle Group.....</i>	<i>3-7</i>
<i>Wiring Group.....</i>	<i>3-9</i>
<i>Wiring Diagram</i>	<i>3-11</i>
<i>Suggested Spare Parts.....</i>	<i>3-11</i>
<i>Warranty</i>	<i>3-12</i>

HOW TO USE THIS MANUAL

This manual contains the following sections:

- HOW TO USE THIS MANUAL
- SAFETY
- OPERATIONS
- MAINTENANCE
- PARTS LIST

The HOW TO USE THIS MANUAL section will tell you how to find important information for ordering correct repair parts.

Parts may be ordered from authorized Windsor dealers. When placing an order for parts, the machine model and machine serial number are important. Refer to the MACHINE DATA box which is filled out during the installation of your machine. The MACHINE DATA box is located on the inside of the front cover of this manual.

MODEL _____
DATE OF PURCHASE _____
SERIAL NUMBER _____
SALES REPRESENTATIVE # _____
DEALER NAME _____
OPERATIONS GUIDE NUMBER _____
PUBLISHED _____

The SAFETY section contains important information regarding hazard or unsafe practices of the machine. Levels of hazards is identified that could result in product or personal injury, or severe injury resulting in death.

The OPERATIONS section is to familiarize the operator with the operation and function of the machine.

The MAINTENANCE section contains preventive maintenance to keep the machine and its components in good working condition.

The PARTS LIST section contains assembled parts illustrations and corresponding parts list. The parts lists include a number of columns of information:

- **REF** – column refers to the reference number on the parts illustration.
- **PART NO.** – column lists the part number for the part.
- **PRV NO.** – reference number.
- **QTY** – column lists the quantity of the part used in that area of the machine.
- **DESCRIPTION** – column is a brief description of the part.
- **SERIAL NO. FROM** – column indicates the first machine the part number is applicable to. When the machine design has changed, this column will indicate serial number of applicable machine. The main illustration shows the most current design of the machine. The boxed illustrations show older designs.
- **NOTES** – column for information not noted by the other columns.

NOTE: If a service or option kit is installed on your machine, be sure to keep the KIT INSTRUCTIONS which came with the kit. It contains replacement parts numbers needed for ordering future parts.

NOTE: The number on the lower left corner of the front cover is the part number for this manual.

IMPORTANT SAFETY INSTRUCTIONS

When using an electrical appliance, basic precaution must always be followed, including the following:

READ ALL INSTRUCTIONS BEFORE USING THIS MACHINE.



To reduce the risk of fire, electric shock, or injury:

Use only indoors. Do not use outdoors or expose to rain.

Use only as described in this manual. Use only manufacturer's recommended components and attachments.

If the machine is **not working properly**, has been dropped, damaged, left outdoors, or dropped into water, return it to an authorized service center.

Do not operate the machine with any openings blocked. Keep openings free of debris that may reduce airflow.

Machine can cause a fire when operating near flammable vapors or materials. Do not operate this machine near flammable fluids, dust or vapors.

This machine is suitable for commercial use, for example in hotels, schools, hospitals, factories, shops and offices for more than normal housekeeping purposes.

Maintenance and repairs **must be done** by qualified personnel.

During operation, attention shall be paid to other persons, especially children.

The machine shall only be operated by instructed and authorized persons.

When leaving unattended, unplug the machine.

Do not handle the plug or machine with wet hands.

Do not unplug machine by pulling on cord. To unplug, grasp the plug, not the cord.

Do not use with damaged cord or plug. Follow all instructions in this manual concerning grounding the machine.

Do not pull or carry by cord, use cord as a handle, close a door on cord, or pull cord around sharp edges or corners.

Do not pull/run machine over cord. **Keep** cord away from heated surfaces.

Connect to a **properly** grounded outlet. See Grounding Instructions.

SAVE THESE INSTRUCTIONS

HAZARD INTENSITY LEVEL

The following symbols are used throughout this guide as indicated in their descriptions:

HAZARD INTENSITY LEVEL

There are three levels of hazard intensity identified by signal words -**WARNING** and **CAUTION** and **FOR SAFETY**. The level of hazard intensity is determined by the following definitions:

WARNING

WARNING - Hazards or unsafe practices which COULD result in severe personal injury or death.

CAUTION

CAUTION - Hazards or unsafe practices which could result in minor personal injury or product or property damage.

FOR SAFETY: To Identify actions which must be followed for safe operation of equipment.

Report machine damage or faulty operation immediately. Do not use the machine if it is not in proper operating condition. Following is information that signals some potentially dangerous conditions to the operator or the equipment. Read this information carefully. Know when these conditions can exist. Locate all safety devices on the machine. Please take the necessary steps to train the machine operating personnel.

FOR SAFETY:

DO NOT OPERATE MACHINE:

Unless Trained and Authorized.

Unless Operation Guide is Read and understood.

In Flammable or Explosive areas.

In areas with possible falling objects.

WHEN SERVICING MACHINE:

Avoid moving parts. Do not wear loose clothing; jackets, shirts, or sleeves when working on the machine. Use Windsor approved replacement parts.

GROUNDING INSTRUCTIONS

THIS PRODUCT IS FOR COMMERCIAL USE ONLY.

ELECTRICAL:

In the USA this machine operates on a one 15 amp nominal 120V, 60 hz, A.C. power circuit. The amp, hertz, and voltage are listed on the data label found on each machine. Using voltages above or below those indicated on the data label will cause serious damage to the motors.

GROUNDING INSTRUCTIONS:

This appliance must be grounded. If it should malfunction or break down, grounding provides a path of least resistance for electric current to reduce the risk of electric shock. This appliance is equipped with a cord having an equipment-grounding conductor and grounding plug. The plug must be inserted into an appropriate outlet that is properly installed and grounded in accordance with all local codes and ordinances.

This appliance is for use on a nominal 120-volt circuit, and has a grounded plug that looks like the plug in "Fig. A". A temporary adaptor that looks like the adaptor in "Fig. C" may be used to connect this plug to a 2-pole receptacle as shown in "Fig. B", if a properly grounded outlet is not available. The temporary adaptor should be used only until a properly grounded outlet (Fig. A) can be installed by a qualified electrician. The green colored rigid ear, lug, or the like extending from the adaptor must be connected to a permanent ground such as a properly grounded outlet box cover. Whenever the adaptor is used, it must be held in place by a metal screw.

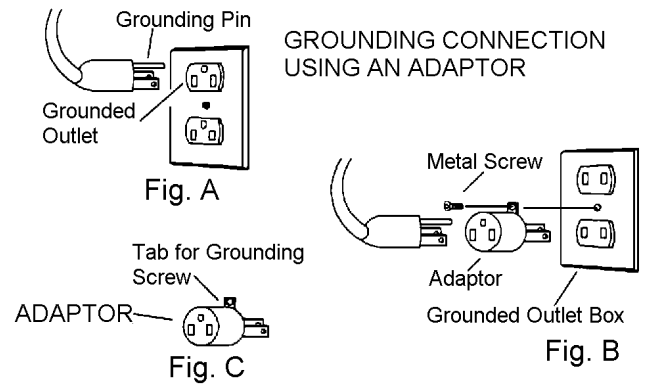

Note: Adaptors are not allowed in Canada.

⚠ WARNING:

Improper connection of the equipment-grounding conductor can result in a risk of electric shock. Check with a qualified electrician or service person if you are in doubt as to whether the outlet is properly grounded. Do not modify the plug provided with the appliance - if it will not fit the outlet, have a proper outlet installed by a qualified electrician.

TECHNICAL SPECIFICATIONS

ITEM	DIMENSION/CAPACITY
Construction	Heavy-duty die cast aluminum deck with heavy-duty rubber bumper, tubular steel adjustable handle with die cast aluminum handle housing
Motor	
SP13, SP15, SP17, SP20	1.0 hp
SP17X, SP20X, SPDS20	1.5 hp
Brush/Pad speed	
SP13, SP15, SP17, SP20, SP17X, SP20X	175 rpm
SPDS20	175/300 rpm
Electrical system	115 volts, 60 Hz
Cable	50' (15 m), 14/3, built in cord wrap
Switches	Dual levers with safety lock
Wheels	Two 5" (12.7 cm) dia., 1.25" (3 cm) wide, non-marking tread
Handle	1.5" (4 cm) tubular steel, adjustable, easy to use thumb activated safety lock
Dimensions (L x W x H)	
13" (33 cm) model	21.0" (53 cm) x 14" (36 cm) x 47" (119 cm)
15" (38 cm) model	22.0" (56 cm) x 16" (41 cm) x 47" (119 cm)
17" (43 cm) model	23.0" (58 cm) x 18" (46 cm) x 47" (119 cm)
20" (51 cm) model	24.5" (62 cm) x 21" (53 cm) x 47" (119 cm)

HANDLE INSTALLATION

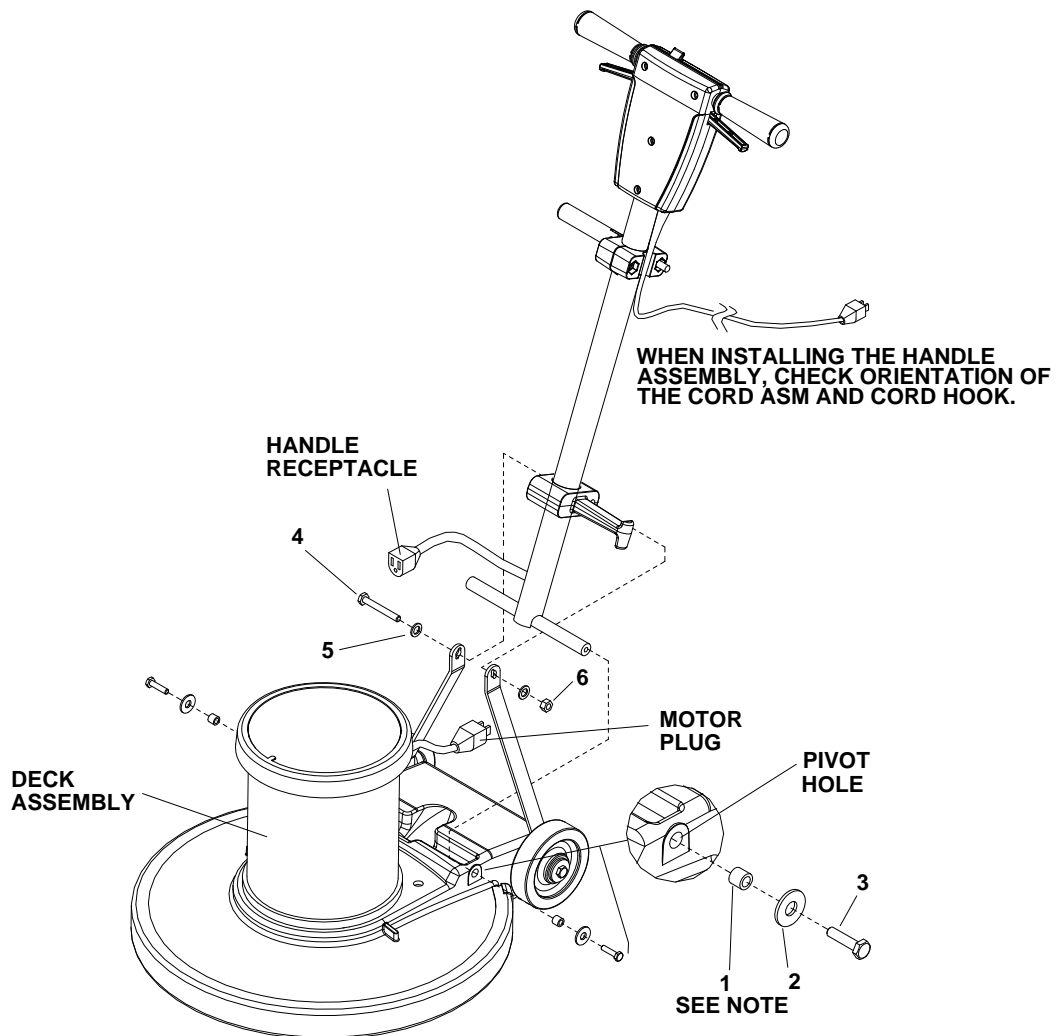

WARNING:

This must be installed by qualified personnel. Read all instructions thoroughly. The machine is shipped with handle unassembled.

The machine is shipped with handle unassembled.

Follow these steps for installation:

1. Remove handle and deck assembly from carton.
2. Attach handle assembly to base using hardware kit (86219680 PRV NO. 47331) (attached to handle in a plastic bag) items 1, 2, and 3.

NOTE: The spacers (items 1) are required for the correct operation of the handle. The spacers are positioned completely inside the pivot holes in the casting, and are held in place by tightening the bolts and washers (items 2 and 3) against the spacer.

3. Remove bolt, nut and washers (items 4, 5 and 6) from lower block on handle assembly. Attach links as shown. Tighten bolt and nut securely, then back off 1/4 to 1/2 turn.
4. Check handle for movement up and down.
5. Plug motor cord into handle cord receptacle.

OPERATION

CONTROLS

1. **Safety Lock** – Prevents unintended operation of the machine.
2. **Switch Levers** – Turns machine on/off.
3. **Adjustment Handle** – Allows the handle to be adjusted to a comfortable operating position.

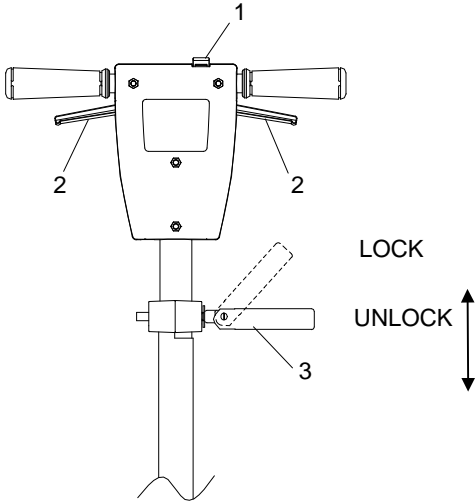

The handle adjust bar (86215130 - PRV NO. 14344) for the polishers are individually preset at the factory for optimum locking efficiency and minimum effort of engaging. It should not be necessary to adjust the handle adjust bar unless the relationship of the handle adjust bar nut (86136360 - PRV NO. 57275) or fixed clamp bolt (86136700 – PRV NO. 70692) and their corresponding nuts (86136360 – PRV NO. 57275) and washer (86010720 – PRV NO. 87086) have been disturbed. The handle can be positioned to be locked with the handle adjust bar pointing either up or down. In order to change the position the handle and bolt must be removed and rotated 180 degrees. It is incorrect to make it lock opposite from the way it was assembled by applying more force to the nut. From the factory the locking is in the up position when the machine handle is locked. The pivot pin (86222560 – PRV NO. 66334) on the handle adjust bar is off center, in relationship of the screw to the axis of the (see drawing). To adjust handle adjust bar, tighten nut on handle while in the locked position. The handle is locked when the screw is to the outside of the machine and the flat on the opposite side of the handle is flush to the bracket.

1. To adjust handle lock, tighten nut on handle while in the locked position. Optimum locking force and ease of locking is accomplished when the locking lever nut is set to a torque of 30 to 50 inch pounds in the locked position.
2. Gap between clamp halves at the front should be to the gap in rear when the handle adjust bar is adjusted properly and in the locked position (gap approximately 1/16").

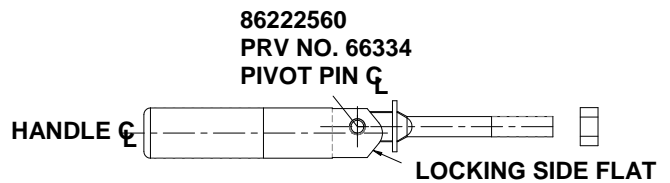
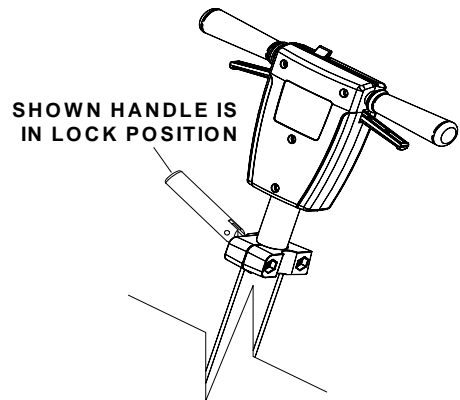
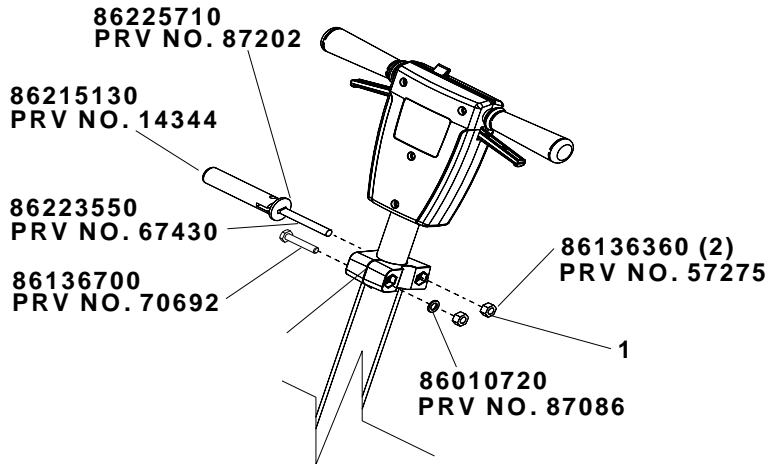

⚠ CAUTION

For indoor use only.

To prevent possible damage to the floor when using the brush option, use water or other approved cleaning solution while operating. When using the pad option, always keep the machine moving when in contact with the floor.

⚠ WARNING

High starting torque. Hold machine firmly with both hands.

1. Ensure that the pad driver or brush is installed correctly and in good shape. Install or change pad if necessary.
2. Plug the machine into a wall outlet as described in the grounding instructions.
3. Lower the handle by unlocking the adjustment handle and moving the handle into position. Relock the handle when it is in a comfortable position.

⚠ WARNING

Insure that handle is locked in position before starting machine.

4. Push the safety lock forward, unlocking the switch levers.
5. With the safety lock forward, squeeze one or both of the switch levers, turning the machine on. (These levers can be operated independently of each other). The safety lock will not re-engage until both levers are released.
6. To stop the machine, release both of the switch levers.

NOTE: The machine is equipped with a circuit breaker to protect the motor in the event an overload condition occurs. The circuit breaker is located on the rear of the motor. Push the reset button to restart the machine. If the breaker trips again, correct the cause of overloading before proceeding.

DAILY MAINTENANCE

1. Inspect power cord for wear. To prevent electrical shock replace cords with frayed or cracked insulation immediately.
2. Place machine in the storage position.
3. Check pad condition. Change if soiled or torn.

PAD DRIVER INSTALLATION

1. Lay machine back, exposing the under side.
2. Place pad driver on the motor lug and rotate clockwise until engaged. To remove, turn counter-clockwise.

PAD INSTALLATION:

Ensure Pad is Centered on Pad Driver. Pull Pad to edge of Pad Driver in several directions to check for proper engagement.

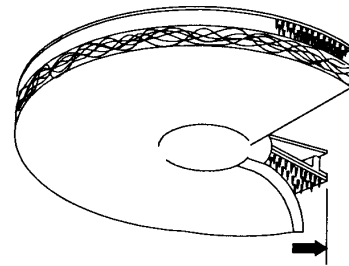

MAINTENANCE

SCRUB BRUSHES

NOTE: All original equipment brushes are equipped with "Perform Alert®". This feature will tell the operator when it is time to replace the scrub brushes. "Perform Alert®" brushes have pre-trimmed bright yellow tufts to indicate the length of a worn out brush. When the tufts in the scrub brush wear to a length equal to the yellow tufts, the scrub brushes should be replaced.

There are five different types of brushes available to cover applications from cleaning heavily soiled floors to polishing. A pad driver is also available to take advantage of the many cleaning pads on the market and further add to the flexibility of the POLISHER.

Please refer to the following to assist in selecting the proper brush or pad for the work at hand.

UNCOATED FLOORS

Aggressive Grit is a nylon fiber impregnated with silicone carbide grit. It grinds away stain, soil, and removes surface material.

Mild Grit is a less aggressive silicone carbide grit suitable for cleaning medium soil conditions. Advantages are faster ground speed than nylon bristles on light solid applications.

Nylon is a general-purpose scrub brush with stiff bristles. Polypropylene works well for maintaining concrete, wood and tile floors.

FINISHED FLOORS

Nylon Polish is the softest brush. It will gently clean finished tile or terrazzo floors without removing floor finish or floor material. Used for washing highly polished or burnished floors.

Nylon bristles are used in a variety of applications on coated or uncoated surfaces.

White Pads (Polishing) are used for dry polishing to achieve a high-gloss appearance, or surface washing on highly polished or burnished floors.

Red Pads (Buffing) are used for light-duty scrubbing. When used with a mild detergent they will provide surface cleaning without removing the finish.

Blue Pads (Scrubbing) are used for heavy-duty scrubbing and light stripping. The blue pads remove less finish than brown stripping pads, yet will remove black marks, stains and dirt.

Brown Pads (Stripping) are used for easy and complete removal of old floor waxes/finishes. They will quickly remove ground in dirt, black heel marks, and spills. When used with the proper stripper, this pad leaves the floor clean and ready for finishing.

The scrub brushes should be checked before each days work for wire, string, wear and damage. The scrub brushes should be replaced if brush bristles are missing or if yellow Perform Alert © indicates minimum brush length.

SERVICE SCHEDULE

MAINTENANCE	DAILY	MONTHLY
Check pad wear to prevent buildup of chemicals	*	
Check pad driver system for damage	*	
Check handles, switches, and knobs for damage	*	
Store with pad off the floor	*	
Check all bearings for noise		*
Check skirt/bumpers for damage and replace as necessary		*
Check overall performance of machine		*

TROUBLESHOOTING

PROBLEM	CAUSE	SOLUTION
Machine will not run	Circuit breaker tripped in building.	Check and reset.
	Power switch failure.	Test switch for continuity and replace if necessary.
	Tripped circuit breaker.	Reset.
	Faulty power cord.	Replace.
	Fuse in motor is blown.	Replace. CAUTION: To reduce the risk of electrical shock, unplug the machine before opening fuse holder. Fuse will only open under extreme conditions. Investigate cause before replacing.
Electrical shock	Equipment not grounded.	Follow grounding instructions exactly.
	Receptacle not grounded.	Have an electrician inspect building's wiring.
	Internal wiring problem	Ensure that the machine wiring matches the appropriate wiring diagram. Replace any wires or components that are short-circuiting.
Repeated circuit breaker tripping	Mechanical problem.	Higher amp draws indicate a mechanical problem, find the problem before using the machine.
	Faulty circuit breaker.	Test circuit for continuity. Replace circuit breaker if necessary.
Excessive vibration	Pad not centered.	Re-center pad.
	Damaged or unevenly worn pad.	Replace pad. Do not rest machine on pad when not in use.
	Damaged pad driver.	Replace.
Pad does not turn but motor is running	Shear coupling has failed.	Replace coupling.

BRUSH/PAD DRIVER GROUP

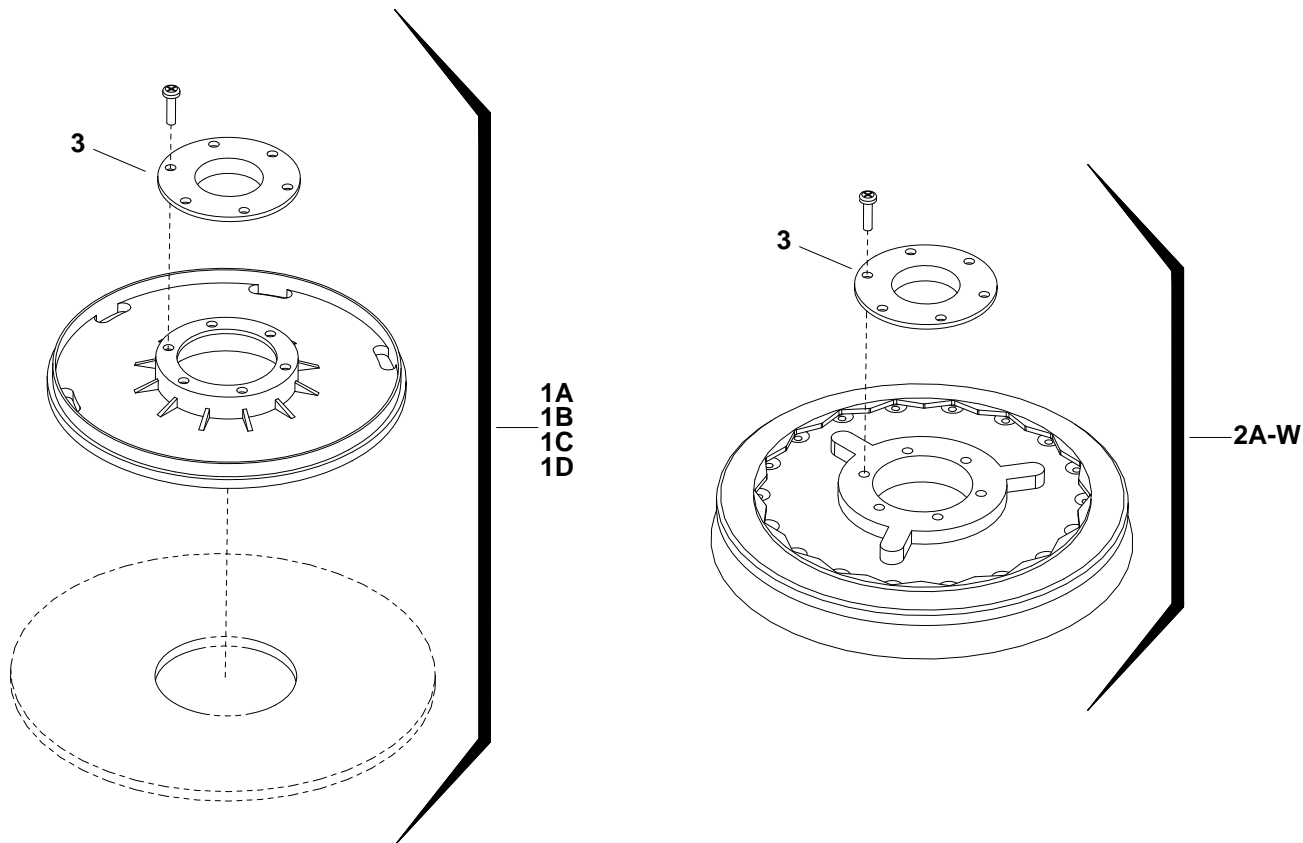

BRUSH/PAD DRIVER GROUP

REF	PART NO.	PRV NO.	QTY	DESCRIPTION	SERIAL NO. FROM	NOTES:
1A	86284280	02216	-	PAD DRIVER, 13" POLISHER		
1B	86284330	02396	-	PAD DRIVER, 15" POLISHER		
1C	86000120	02218	-	PAD DRIVER, 17" POLISHER		
1D	86284300	02219	-	PAD DRIVER, 20" POLISHER		
2A	86283720	02232	-	BRUSH, 13" NYL.POL. W/CLT.PLT		
2B	86283730	02233	-	BRUSH, 13" NYL.SCRUB W/CLT.PLT		
2C	86283740	02234	-	BRUSH, 13" MILD GRIT W/CLT.PLT		
2D	86283750	02235	-	BRUSH, 13" AGG. GRIT W/CLT.PLT		
2E	86283760	02236	-	BRUSH, 13" POLYPRO W/CLT. PLT		
2F	86230480	02447	-	BRUSH, 15" NYL.POL. W/CLT.PLT		
2G	86230490	02448	-	BRUSH, 15" NYL. SCRUB W/CLT.PLT		
2H	86230460	02445	-	BRUSH, 15" MILD GRIT W/CLT.PLT		
2J	86230450	02444	-	BRUSH, 15" AGG.GRIT W/CLT.PLT		
2K	86230470	02446	-	BRUSH, 15" PLOYPRO W/CLT.PLT		
2L	86000140	02242	-	BRUSH, 17" NYL. POL. W/CLT.PLT		
2M	86283800	02240	-	BRUSH, 17" NYL.SCRUB W/CLT.PLT		
2N	86000130	02241	-	BRUSH, 17" MILD GRIT W/CLT.PLT		
2P	86283710	02205	-	BRUSH, 17" AGG. MALGRIT W/C.P		
2Q	86000110	02206	-	BRUSH, 17" POLYPRO W/CLT. PLT		
2R	86283790	02239	-	BRUSH, 20" NYL.POL.W/CLT.PLT.SFT		
2T	86283770	02237	-	BRUSH, 20" NYL.SCRUB W/CLT.PLT		
2U	86283780	02238	-	BRUSH, 20" MILD GRIT W/CLT.PLT		
2V	86283690	02202	-	BRUSH, 20" AGG. MALGRIT W/C.P.		
2W	86283700	02203	-	BRUSH, 18" POLYPRO W/CLT. PLT		
3	86284350	02220	-	PLATE, PAD CLUTCH		

FRAME GROUP

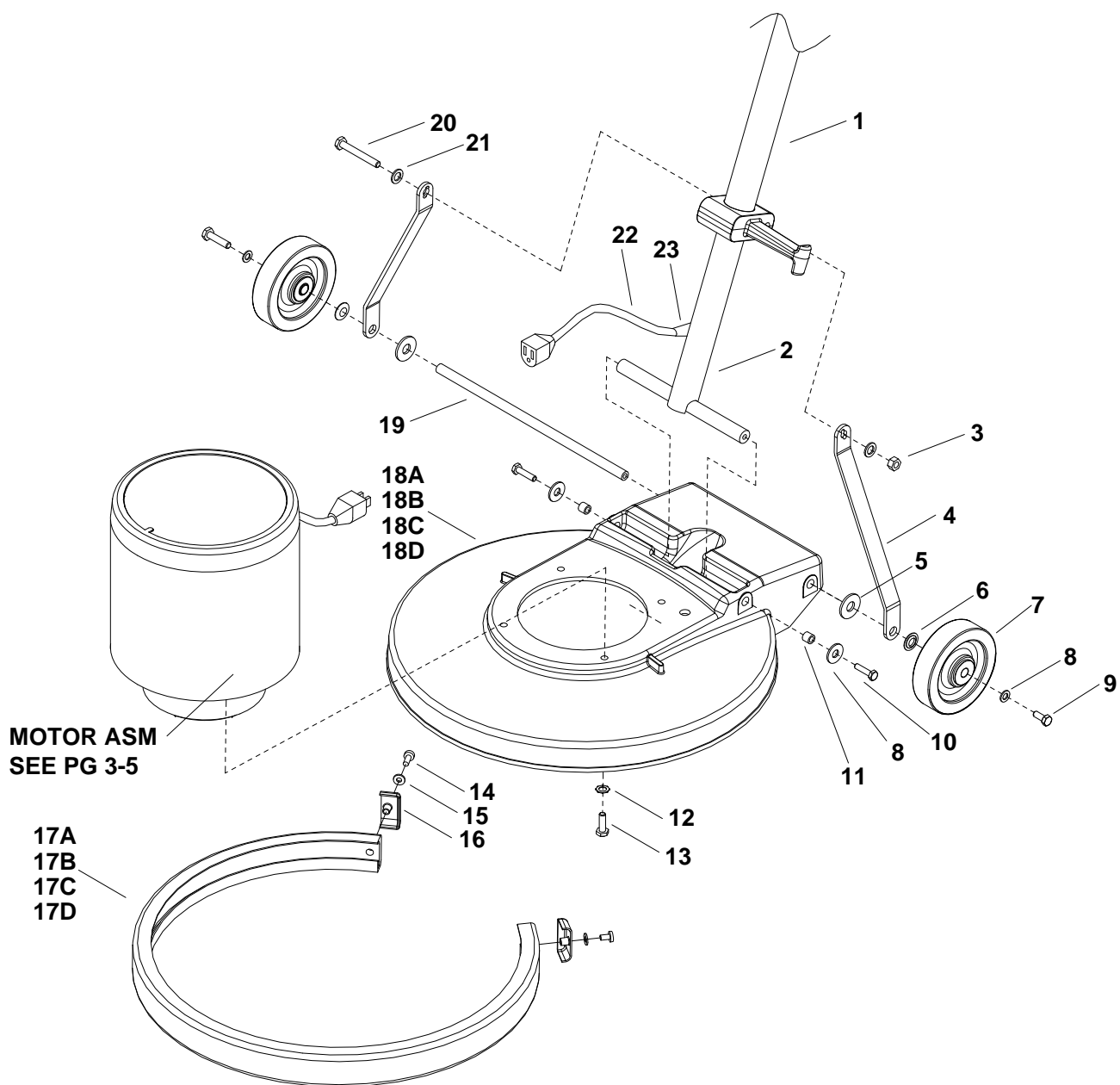

FRAME GROUP

REF	PART NO.	PRV NO.	QTY	DESCRIPTION	SERIAL NO. FROM	NOTES:
1	86225380	78447	1	TUBE ASSY, HANDLE ADJ		
2	86218440	38290	1	HANDLE, POLISHER		
3	86136360	57275	1	NUT, M10X1.5 HEX NYLOCK PLTD		
4	86221860	51328	2	LINK, HANDLE ADJUST		
5	86225720	87203	2	WASHER, 14MMID X 36MMOD		
6	86222270	57276	2	NUT, PUSH FLAT RD .51D		
7	86226020	89206	2	WHEEL, 5D X 1.25 X 13MMID GRY		
8	86137280	87054	2	WASHER, M8 FLAT DIN125A PLT		
9	86136640	70262	2	SCR, M8-1.25 HHMS PLTD		
10	86274230	70135	2	SCR, M8 X 30 HHMS		
11	86224290	730008	2	SPACER, .317ID X .50D X .44LG		
12	86279090	87067	4	WASHER, 5/16 LOCK INT STAR PLT		
13	86136710	70698	4	SCR,5/16-18 X 3/4 HHCS GR5 BLK		
14	86276570	70691	2	SCR, M6 X 25 HHMS BLK		
15	86137340	87211	2	WASHER, M6 FLAT BLK		
16	86216600	27871	2	CAP, EXTRUSION		
17A	86216320	14341	-	BUMPER, EXTRUSION 30.5"		
17B	86216330	14371	-	BUMPER, EXTRUSION 37.3"		
17C	86216340	14372	-	BUMPER, EXTRUSION 43.8"		
17D	86216350	14373	-	BUMPER, EXTRUSION 53.4"		
18A	86288430	29211	-	DECK, 13 IN POLISHER, BLUE		
18B	86288440	29212	-	DECK, 15 IN POLISHER, BLUE		
18C	86217600	29213	-	DECK, 17 IN POLISHER, BLUE		
18D	86217610	29214	-	DECK, 20 IN POLISHER, BLUE		
19	86214930	03111	1	AXLE, MAIN POLISHER		
20	86136720	70701	1	SCR, M10 X 90 HHMS		
21	86010720	87086	2	WASHER, M10 X 30 PLTD		
22	86216920	23206	1	CORDSET, 14/3 X 47", SJT, BLK		
23	86224930	730012	1	STRAIN RELIEF, 14/3 STRAIGHT		

MOTOR GROUP

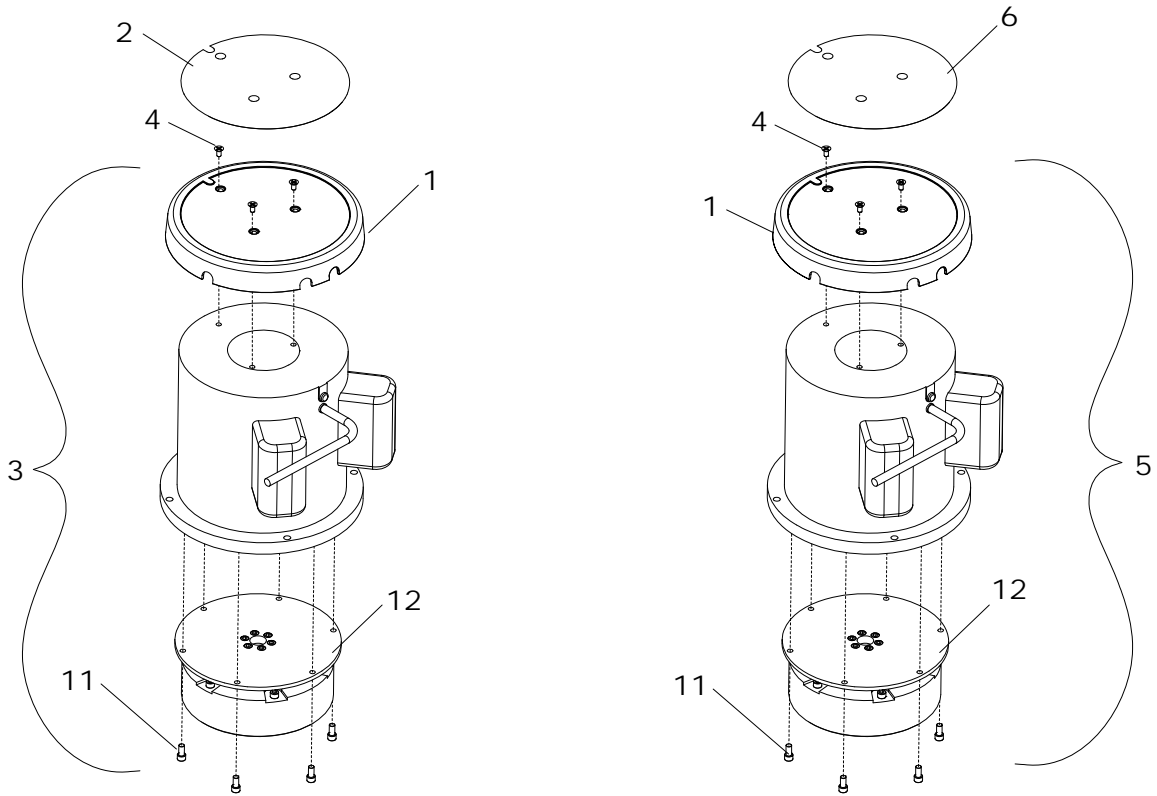

SP13, SP15, SP17, SP20
10090220, 10090230, 10090240, 10090310

SP17X, SP20X
10090280, 10090320

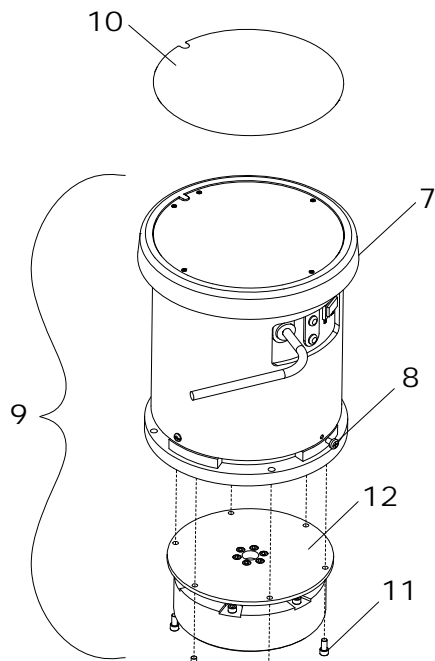

SPDS20
10090350

MOTOR GROUP

REF	PART NO.	PRV NO.	QTY	DESCRIPTION	SERIAL NO. FROM	NOTES:
1	86217490	27884	1	COVER, MOTOR		
2	86220020	500763	1	LABEL, STORM MAIN		
3	86222090	53263	1	MOTOR, 1 HP 115V INDUCTION		SPT13/15/17/20
4	86223690	70702	3	SCR, M5 X .8 X 15MM BLK		
5	86222100	53264	1	MOTOR, 1.5 HP 115V INDUCTION		INCLUDES ITEM 4, 1, 12, & 11 (SP17X/20X)
6	86220030	500764	1	LABEL, STORM DELUXE MAIN		
7	86217500	27892	1	COVER, ASM, MOTOR		
8	86223680	70700	8	SCR, M5 X .8 X 10MM PHMS BLK		
9	86222070	53253	1	MOTOR, 115V 1.75 HP 175/300 RPM		SPDS20
10	86220040	500765	1	LABEL, STORM DUAL SPEED MAIN		
11	86223700	70723	6	SCR, M5 X .8 X 15MM SHCSM		
12	86223030	62917	1	PLATE, ADAPTER MOTOR		

MOTOR COMPONENTS (NOT SHOWN)

PART NO.	PRV NO.	QTY	DESCRIPTION	SERIAL NO. FROM	NOTES:
86216710	140411	1	CIRCUIT BREAKER, 20 AMP		SP13/15/17/17X/20/20X
86216700	140401	1	CIRCUIT BREAKER, 30 AMP		SPDS20
86223390	67488	1	RECTIFIER, 50A 600V BRIDGE		SPDS20
86001820	14404	1	BRUSH SET MOTOR (PKG OF 4)		SPDS20
86003660	34378	1	FUSE		
86003670	34379	1	FUSE HOLDER		
86001020	09135	2	BEARING, MOTOR		
86135540	27352	1	COUPLING, MTR/GEAR BOX		
86225170	730039	1	SWITCH ASM, DUAL SPEED		SPDS20 (FOR 2 SPEED ONLY)
86215410	140416	1	BOOT, CIRCUIT BREAKER		
86223510	67489	1	RING, MOTOR SHAFT		
86214740	05176	1	ARMATURE, MOTOR REPAIR 53253		SPDS20
86002650	270061	1	CAPACITOR, RUN 30UF		SP13/15/17/17X/20/20X
86216610	270062	1	CAPACITOR, START 340UF		SP13/15/17/17X/20/20X
86216650	72182	1	CENTRIFUGAL WEIGHT ASSEMBLY		SP13/15/17/17X/20/20X
86224890	72183	1	STATIONARY END CAP SWITCH		SP13/15/17/17X/20/20X

HANDLE GROUP

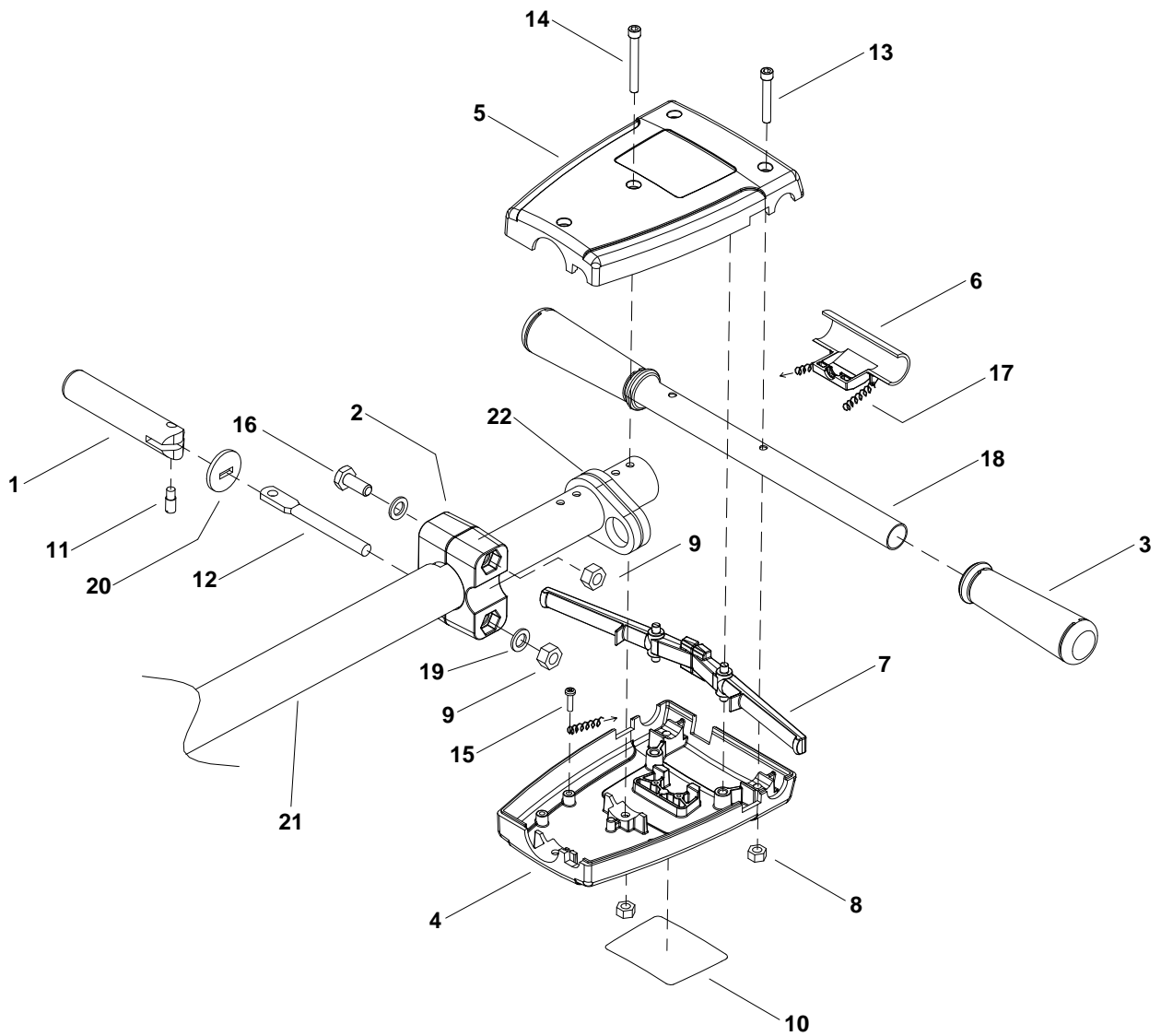

HANDLE GROUP

REF	PART NO.	PRV NO.	QTY	DESCRIPTION	SERIAL NO. FROM	NOTES:
1	86215130	14344	1	BAR, HANDLE ADJUST		
2	86215380	140393	1	BLOCK, HANDLE MOUNT		
3	86004070	36196	2	GRIP, POLISHER HANDLE		
4	86219320	41363	1	HOUSING, POLISHER HANDLE REAR		
5	86219330	41366	1	HOUSING, POLISHER HANDLE FRONT		
6	86005150	51326	1	LOCK, SAFETY HANDLE		
7	86005160	51327	2	LEVER, SWITCH		
8	86136350	57274	4	NUT, M6 HEX FINISH		
9	86136360	57275	1	NUT, M10X1.5 HEX NYLOCK PLTD		
10	86219740	500194	1	LABEL, WARNING		
11	86222560	66334	1	PIN, PIVOT, HANDLE ADJUSTMENT		
12	86223550	67430	1	ROD, HANDLE ADJUST		
13	86136670	70686	2	SCR, M6 X 45 SHCS BLK		
14	86136680	70687	2	SCR, M6 X 50 SHCS BLK		
15	86288450	70689	1	SCR, M4.8 X 10 HHTF TYPE B		
16	86136700	70692	1	SCR, M10 X 75 HHCS PLTD		
17	86224740	73990	2	SPRING, EXT, .5OD X 3.5L		
18	86225370	78437	1	TUBE, GRIP HANDLE		
19	86010720	87086	2	WASHER, M10 X 30 PLTD		
20	86225710	87202	1	WASHER, BEARING (HANDLE ADJ)		
21	86225380	78447	1	TUBE ASSY, HANDLE ADJ		
22	86216370	14434	2	BUMPER, HANDLE		

WIRING GROUP

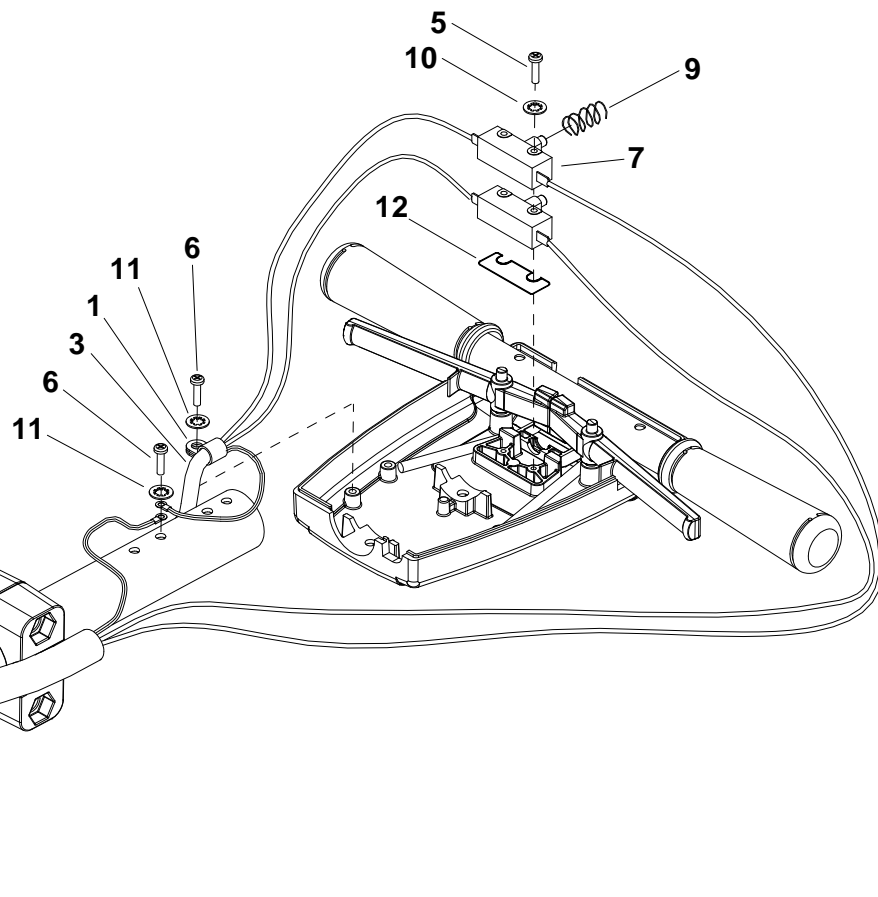
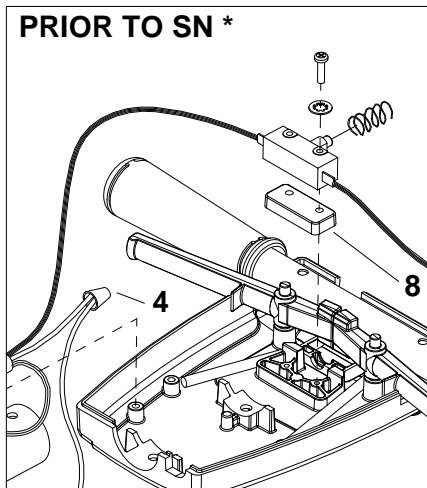

WIRING GROUP

REF	PART NO.	PRV NO.	QTY	DESCRIPTION	SERIAL NO. FROM	NOTES:
1	86233170	20054	1	CLAMP, 3/8 NYLON UL/CSA		
2	86234150	23167	1	CORD SET, 14/3 STO X 50' YLW		
3	86216920	23206	1	CORDSET, 14/3 X 52"SJT, BLK		
4	86247920	57069	1	NUT, ORG WIRE (2-5 18G/2-14G)		
5	86136780	70801	2	SCR, M3.5 X 40 PHTF TYPE B	10020019	WAS 70688
6	86288450	70689	2	SCR, M4.8 X 10 HHTF TYPE B		
7	86007110	72123	2	SWITCH, 25A SPST 125-250V SNAP	10020019	WAS QTY 1
8	86224550	73989	1	SPACER, SWITCH POLISHER		
9	86224750	73993	1	SPRING, COMP, .48OD X .91L		
10	86137290	87057	2	WASHER, M4 SHAKEPROOF		
11	86137330	87208	2	WASHER, M5 SHAKEPROOF PLTD		
12	86215140	140674	1	BARRIER SHEET	10020019	

WIRING DIAGRAM / SPARE PARTS

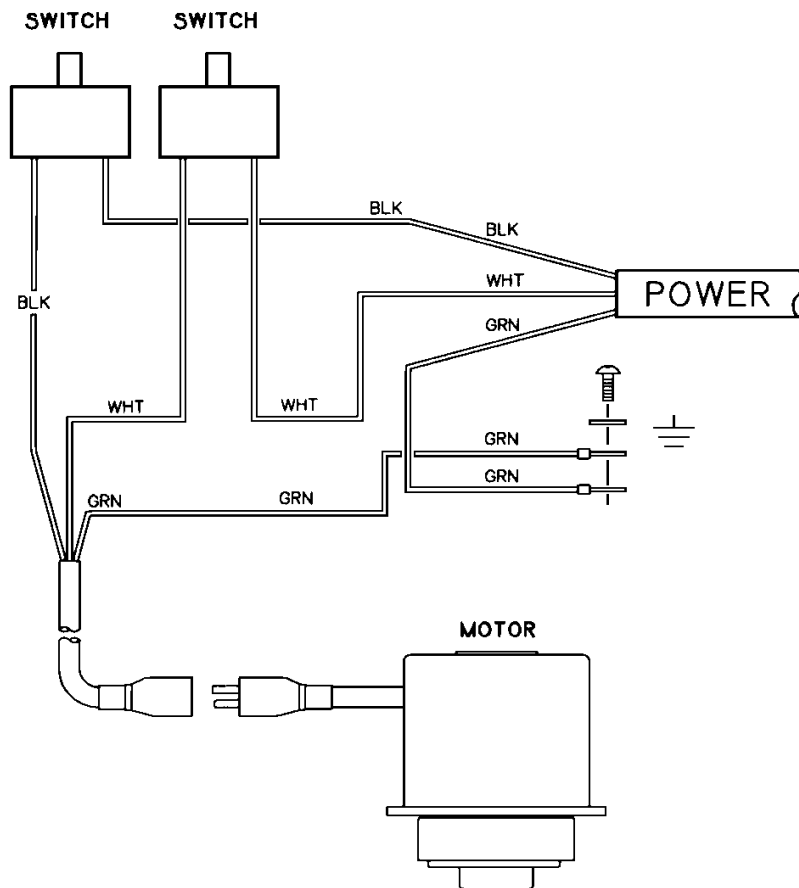

SUGGESTED SPARE PARTS

PART NO.	PRV NO.	DESCRIPTION	SERIAL NO. FROM	NOTES:
86225710	87202	WASHER, BEARING (HANDLE ADJ)		
86224740	73990	SPRING, EXT .5 OD X 3.5L		
86224750	73993	SPRING, COMP .48 OD X .91 L		
86007110	72123	SWITCH. 25A SPST 125-250V SNAP		
86215130	14344	BAR, HANDLE ADJ		
86222560	66334	PIN, PIVOT, HANDLE ADJ		
86223550	67430	ROD, HANDLE ADJ		
86003660	34378	FUSE		
86003670	34379	FUSE HOLDER		
86135540	27352	COUPLING, MTR/GEAR BOX PLSHER		
86223390	67488	RECTIFIER, 50A 600V BRIDGE		SPDS20
86216700	140401	CIRCUIT BREAKER, 30AMP MPX		
86216710	140411	CIRCUIT BREAKER, 20AMP MP/MB		