

CLIPPER

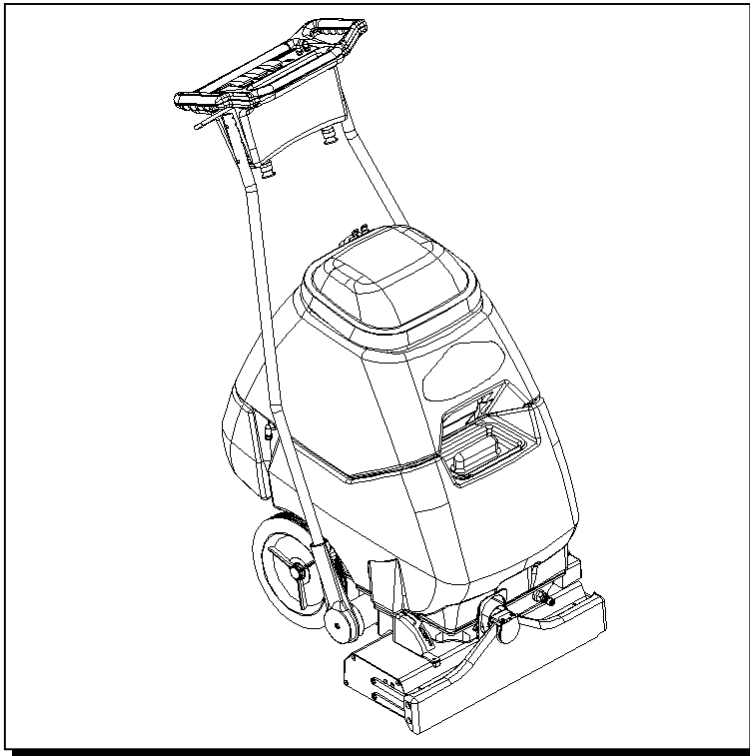

CARPET EXTRACTOR



Operating Instructions

MODEL: CLP12
10080250

QUEST® ... for Continuous Improvement.
Windsor's Quality Management System is Certified ISO 9001.



Read these instructions before operating the machine



86038240 03/19/07

PRV NO. 98630

MACHINE DATA LOG/OVERVIEW

MODEL _____

DATE OF PURCHASE _____

SERIAL NUMBER _____

SALES REPRESENTATIVE # _____

DEALER NAME _____

OPERATIONS GUIDE NUMBER _____

PUBLISHED _____

YOUR DEALER

Name: _____

Address: _____

Phone Number: _____

TABLE OF CONTENTS

<i>Machine Data Log/Overview.....</i>	<i>1</i>
<i>Table of Contents.....</i>	<i>2</i>

HOW TO USE THIS MANUAL

<i>How to use this Manual.....</i>	<i>1-1</i>
------------------------------------	------------

SAFETY

<i>Important Safety Instructions</i>	<i>2-1</i>
<i>Hazard Intensity Level</i>	<i>2-2</i>
<i>Grounding Instructions.....</i>	<i>2-3</i>

OPERATIONS

<i>Technical Specifications.</i>	<i>3-1</i>
<i>Controls/Component Location</i>	<i>3-2</i>
<i>Filling Operation.....</i>	<i>3-5</i>
<i>Operations.</i>	<i>3-6</i>
<i>Cleaning Procedure.</i>	<i>3-8</i>
<i>Accessory Tool Usage.....</i>	<i>3-11</i>

MAINTENANCE

<i>Service Schedule</i>	<i>4-1</i>
<i>Periodic Maintenance.</i>	<i>4-2</i>
<i>Daily/ Regular Maintenance.....</i>	<i>4-2</i>
<i>Vacuum Motor Replacement</i>	<i>4-3</i>
<i>Belt Replacement.....</i>	<i>4-4</i>
<i>Solution Pump Replacement</i>	<i>4-5</i>
<i>Wiring Diagram.</i>	<i>4-6</i>
<i>Troubleshooting Chart</i>	<i>4-7</i>

GROUP PARTS LIST

<i>Frame Assembly.....</i>	<i>5-1</i>
<i>Brush Assembly.....</i>	<i>5-3</i>
<i>Pump Assembly.....</i>	<i>5-5</i>
<i>Vacuum Shoe Assembly.....</i>	<i>5-7</i>
<i>Control Panel Assembly.....</i>	<i>5-9</i>
<i>Solution Tank Assembly.</i>	<i>5-11</i>
<i>Recovery Tank Assembly.</i>	<i>5-13</i>
<i>Suggested Spare Parts/Notes</i>	<i>5-15</i>

HOW TO USE THIS MANUAL

This manual contains the following sections:

- HOW TO USE THIS MANUAL
- SAFETY
- OPERATIONS
- MAINTENANCE
- PARTS LIST

The HOW TO USE THIS MANUAL section will tell you how to find important information for ordering correct repair parts.

Parts may be ordered from authorized dealers. When placing an order for parts, the machine model and machine serial number are important. Refer to the MACHINE DATA box which is filled out during the installation of your machine. The MACHINE DATA box is located on the inside of the front cover of this manual.

MODEL _____
DATE OF PURCHASE _____
SERIAL NUMBER _____
SALES REPRESENTATIVE # _____
DEALER NAME _____
OPERATIONS GUIDE NUMBER _____
PUBLISHED _____

The model and serial number of your machine is on the bottom back-end of the machine.

The SAFETY section contains important information regarding hazard or unsafe practices of the machine. Levels of hazards is identified that could result in product or personal injury, or severe injury resulting in death.

The OPERATIONS section is to familiarize the operator with the operation and function of the machine.

The MAINTENANCE section contains preventive maintenance to keep the machine and its components in good working condition. They are listed in this general order:

- Periodic
- Daily/Regular
- Troubleshooting

The PARTS LIST section contains assembled parts illustrations and corresponding parts list. The parts lists include a number of columns of information:

- **REF** – column refers to the reference number on the parts illustration.
- **PART NO.** – column lists the part number for the part.
- **PRV NO.** – reference number.
- **QTY** – column lists the quantity of the part used in that area of the machine.
- **DESCRIPTION** – column is a brief description of the part.
- **SERIAL NO. FROM** – column indicates the first machine the part number is applicable to. When the machine design has changed, this column will indicate serial number of applicable machine. The main illustration shows the most current design of the machine. The boxed illustrations show older designs. If column has an asterisk (*), call manufacturer for serial number.
- **NOTES** – column for information not noted by the other columns.

NOTE: If a service or option kit is installed on your machine, be sure to keep the KIT INSTRUCTIONS which came with the kit. It contains replacement parts numbers needed for ordering future parts.

NOTE: The number on the lower left corner of the front cover is the part number for this manual.

IMPORTANT SAFETY INSTRUCTIONS
When using an electrical appliance, basic precaution must always be followed, including the following:

READ ALL INSTRUCTIONS BEFORE USING THIS MACHINE.

This machine is for commercial use.



WARNING:

To reduce the risk of fire, electric shock, or injury:

Connect to a **properly grounded outlet**. See Grounding Instructions.

Do not leave the machine unattended. Unplug machine from outlet when not in use and before maintenance or service.

Use only indoors. Do not use outdoors or expose to rain.

Do not allow machine to be used as a toy. **Close attention** is necessary when used by or near children.

Use only as described in this manual. Use only manufacturer's recommended components and attachments.

Do not use damaged electrical cord or plug. Follow all instructions in this manual concerning grounding the machine. If the machine is **not working properly**, has been dropped, damaged, left outdoors, or dropped into water, return it to an authorized service center.

Do not pull or carry machine by electrical cord, use as a handle, close a door on cord, or pull cord around sharp edges or corners.

Do not run machine over cord. **Keep** cord away from heated surfaces.

Do not unplug machine by pulling on cord. To unplug, grasp the electrical plug, not the electrical cord.

Do not handle the electrical plug or machine with wet hands.

Do not operate the machine with any openings blocked. Keep openings free of debris that may reduce airflow.

This machine is intended for cleaning carpet only.

Do not vacuum anything that is burning or smoking, such as cigarettes, matches, or hot ashes.

This machine is not suitable for picking up health endangering dust.

Turn off all controls before unplugging.

Machine can cause a fire when operating near flammable vapors or materials. Do not operate this machine near flammable fluids, dust or vapors.

This machine is suitable for commercial use, for example in hotels, schools, hospitals, factories, shops and offices for more than normal housekeeping purposes.

Maintenance and repairs must be done by qualified personnel.

If foam or liquid comes out of machine, switch off immediately.

SAVE THESE INSTRUCTIONS

HAZARD INTENSITY LEVEL

The following symbols are used throughout this guide as indicated in their descriptions:

HAZARD INTENSITY LEVEL

There are three levels of hazard intensity identified by signal words -**WARNING** and **CAUTION** and **FOR SAFETY**. The level of hazard intensity is determined by the following definitions:



WARNING - Hazards or unsafe practices which COULD result in severe personal injury or death.



CAUTION - Hazards or unsafe practices which could result in minor personal injury or product or property damage.

FOR SAFETY: To identify actions which must be followed for safe operation of equipment.

Report machine damage or faulty operation immediately. Do not use the machine if it is not in proper operating condition. Following is information that signals some potentially dangerous conditions to the operator or the equipment. Read this information carefully. Know when these conditions can exist. Locate all safety devices on the machine. Please take the necessary steps to train the machine operating personnel.

FOR SAFETY:

DO NOT OPERATE MACHINE:

Unless Trained and Authorized.

Unless Operation Guide is Read and understood.

In Flammable or Explosive areas.

In areas with possible falling objects.

WHEN SERVICING MACHINE:

Avoid moving parts. Do not wear loose clothing; jackets, shirts, or sleeves when working on the machine. Use manufacturer approved replacement parts.

GROUNDING INSTRUCTIONS

THIS PRODUCT IS FOR COMMERCIAL USE ONLY.

ELECTRICAL:

In the USA this machine operates on a standard 15 amp 115V, 60 hz, A.C. power circuit . The amp, hertz, and voltage are listed on the data label found on each machine. Using voltages above or below those indicated on the data label will cause serious damage to the motors.

GROUNDING INSTRUCTIONS:

This appliance must be grounded. If it should malfunction or break down, grounding provides a path of least resistance for electric current to reduce the risk of electric shock. This appliance is equipped with a cord having an equipment-grounding conductor and grounding plug. The plug must be inserted into an appropriate outlet that is properly installed and grounded in accordance with all local codes and ordinances.

This appliance is for use on a nominal 115-volt circuit, and has a grounded plug that looks like the plug in "Fig. A". A temporary adaptor that looks like the adaptor in "Fig . C" may be used to connect this plug to a 2-pole receptacle as shown in "Fig. B", if a properly grounded outlet is not available. The temporary adaptor should be used only until a properly grounded outlet (Fig. A) can be installed by a qualified electrician. The green colored rigid ear, lug, or the like extending from the adaptor must be connected to a permanent ground such as a properly grounded outlet box cover. Whenever the adaptor is used, it must be held in place by a metal screw.

WARNING:

Improper connection of the equipment-grounding conductor can result in a risk of electric shock. Check with a qualified electrician or service person if you are in doubt as to whether the outlet is properly grounded. Do not modify the plug provided with the appliance - if it will not fit the outlet, have a proper outlet installed by a qualified electrician.

PROPER GROUNDING

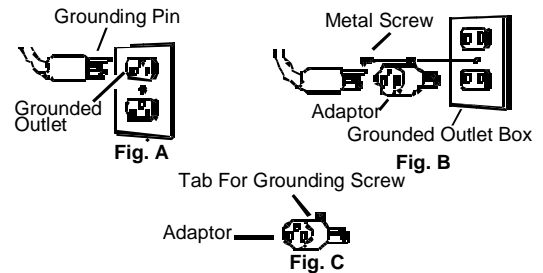

NOTE: In Canada, the use of a temporary adaptor is not permitted by the Canadian Electrical Code

TECHNICAL SPECIFICATIONS

POWER TYPE

ELECTRICAL: 115 V, 15 A, 60 HZ

ELECTRIC VACUUM MOTOR: (1) –3 stage, 1 hp, 99 cfm (2.80 cubic meters/min.) Waterlift –117" (297cm)

BRUSH: (1) 18" (45.7 cm.)

SOLUTION PUMP: 100 PSI, diaphragm style, internal bypass

SOLUTION CAPACITY: 12 gallons (45.5ltr)

RECOVERY CAPACITY: 12 gallons (45.5ltr)

BRUSH SPEED: 1000 rpm

GENERAL DIMENSIONS/WEIGHT

Vacuum shoe: 20" (51 cm) cast aluminum with spring loaded down pressure

WHEELS: (2) 10" dia. (25 cm) wheels by 2"

WEIGHT: 105lbs. (48kg)

LENGTH: 28" (71 cm)

HEIGHT: 46" (117 cm)

WIDTH: 24" (61 cm)

SOLUTION SPRAY: 2 quick change jets.

POWER CABLE: 50' (12.7 m) (14 gauge)

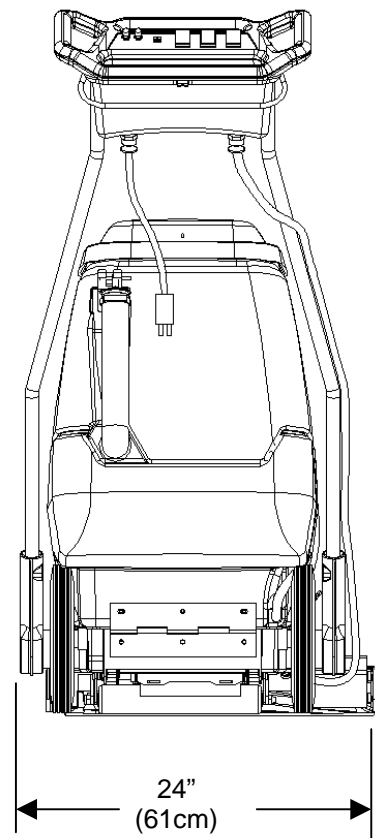
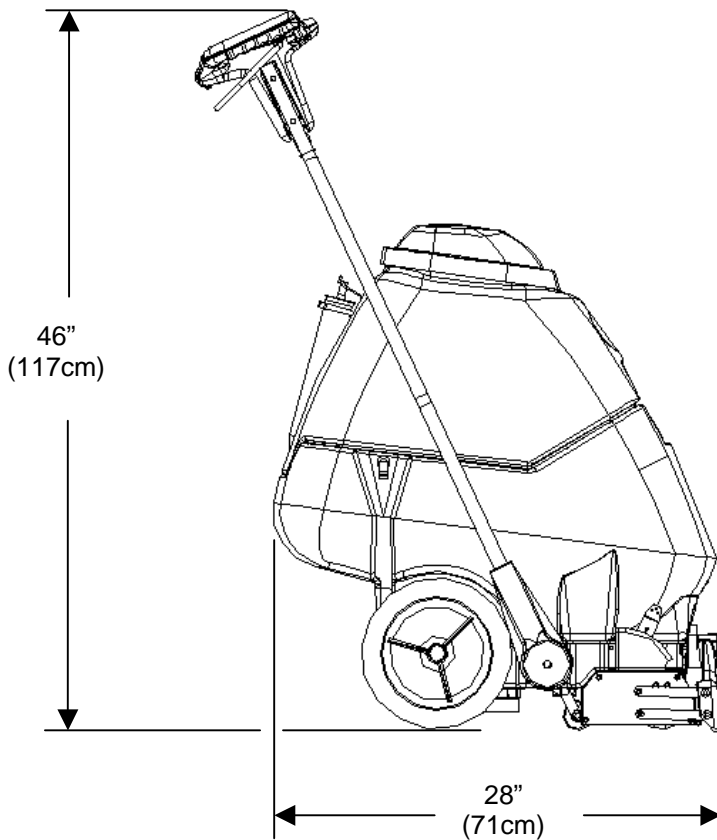

CONTROLS/COMPONENT LOCATIONS

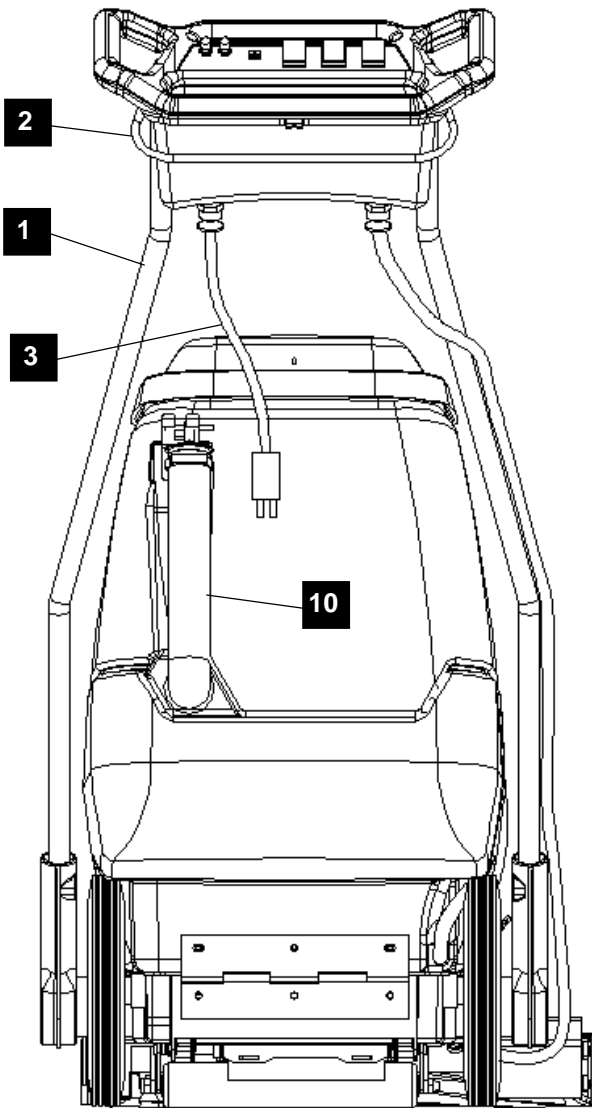
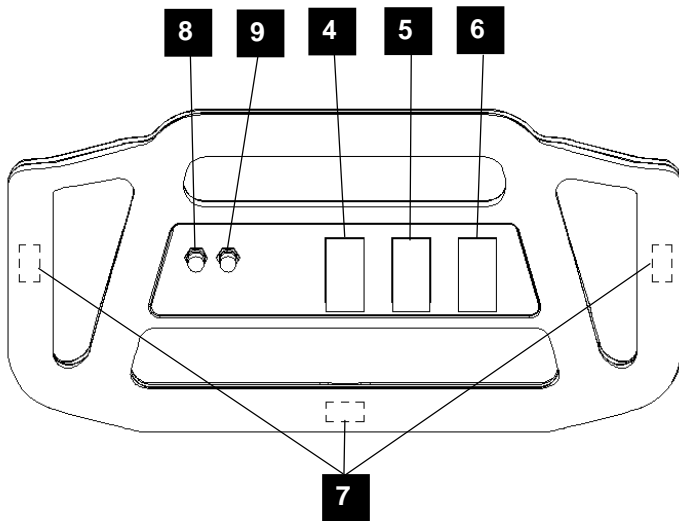

1. **Main Handle.** Used to pull and maneuver machine.
2. **Handle Adjustment.** Used to adjust height of handle, and allow machine to be used in "PUSH" or "PULL" orientation.
3. **Electrical Cord.**
4. **Solution Switch.** Turns on pump. Continuous position (bottom) activates electro-valve to dispense solution to floor through jets. Intermittent position (up) requires operator to depress 1 of 3 trigger switches to dispense solution. Center position is off.
5. **Brush Motor Switch.** Turns on brush motor.
6. **Vacuum Motor Switch.** Turns on vacuum motor.
7. **Trigger Switches.** Activates electro-valve to dispense solution to floor through jets when solution switch is in the intermittent position.
8. **Brush Motor Circuit Breaker.** 6 amp. Breaker protecting brush motor.
9. **Vacuum Motor Circuit Breaker.** 15 amp. Breaker protecting vacuum motor.
10. **Recovery Dump Hose.** Facilitates draining dirty cleaning solution.

CONTROLS/COMPONENT LOCATIONS

1. **Solution Accessory Tool Hookup.** Used for various auxiliary cleaning tools.
2. **Vacuum Hose Door.** Used to connect various auxiliary 1 ½ inch cleaning tool vacuum hoses.
3. **Brush Height Adjustment.** Used to regulate brush height from storage position to various carpet heights.
4. **Recovery Tank.** Used to collect dirty cleaning solution.
5. **Solution Tank.** Used to hold cleaning solution.
6. **Solution Dump Hose.** Facilitates draining excess cleaning solution from solution tank.
7. **Recovery Tank Dome.**
8. **Solution Tank Lid.**
9. **Solution Tank Fill Hose.**
10. **Vacuum Shoe.**
11. **Brush Housing.**
12. **Front Lifting Handle.**
13. **Cleaning Solution Filter.**

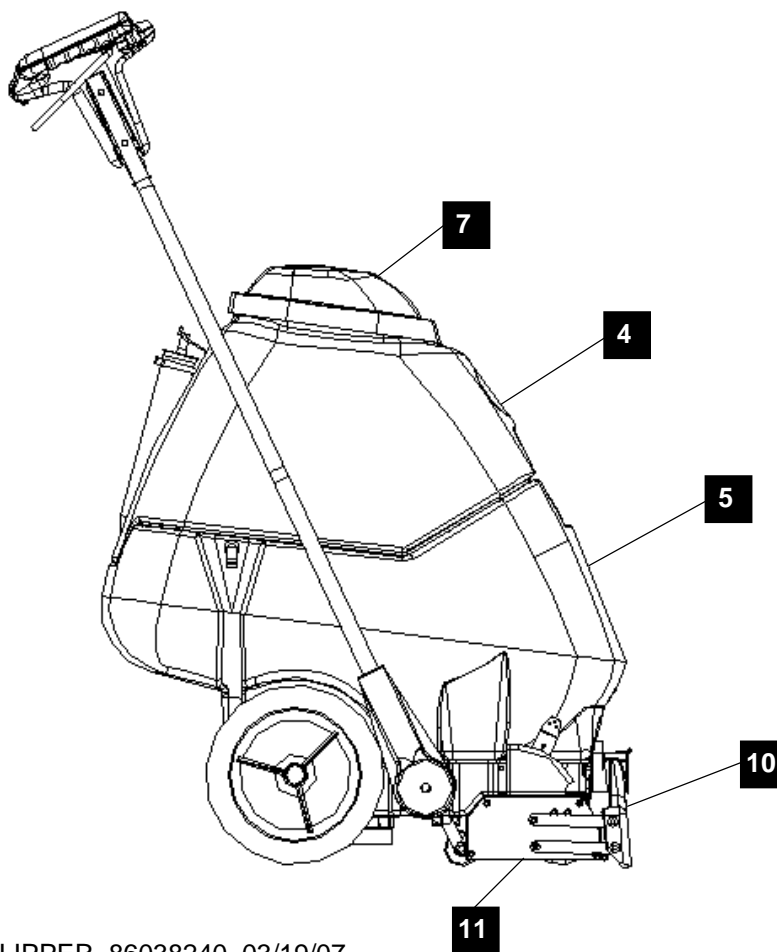
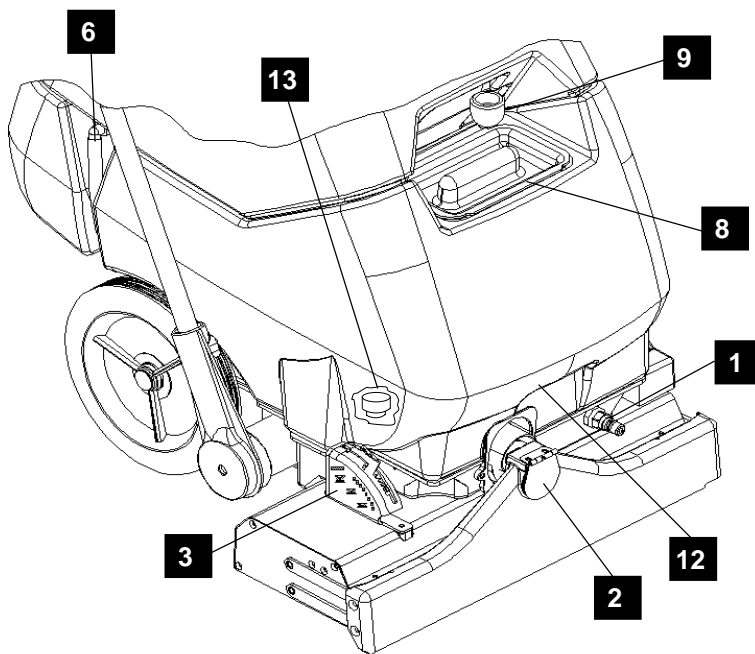

CONTROLS/COMPONENT LOCATIONS

1. Solution Intake Cover.
2. Vacuum Intake Cover.
3. Float Shut-Off.
4. Clean-Out Opening.
5. Pour Spout.
6. Lift Handle.

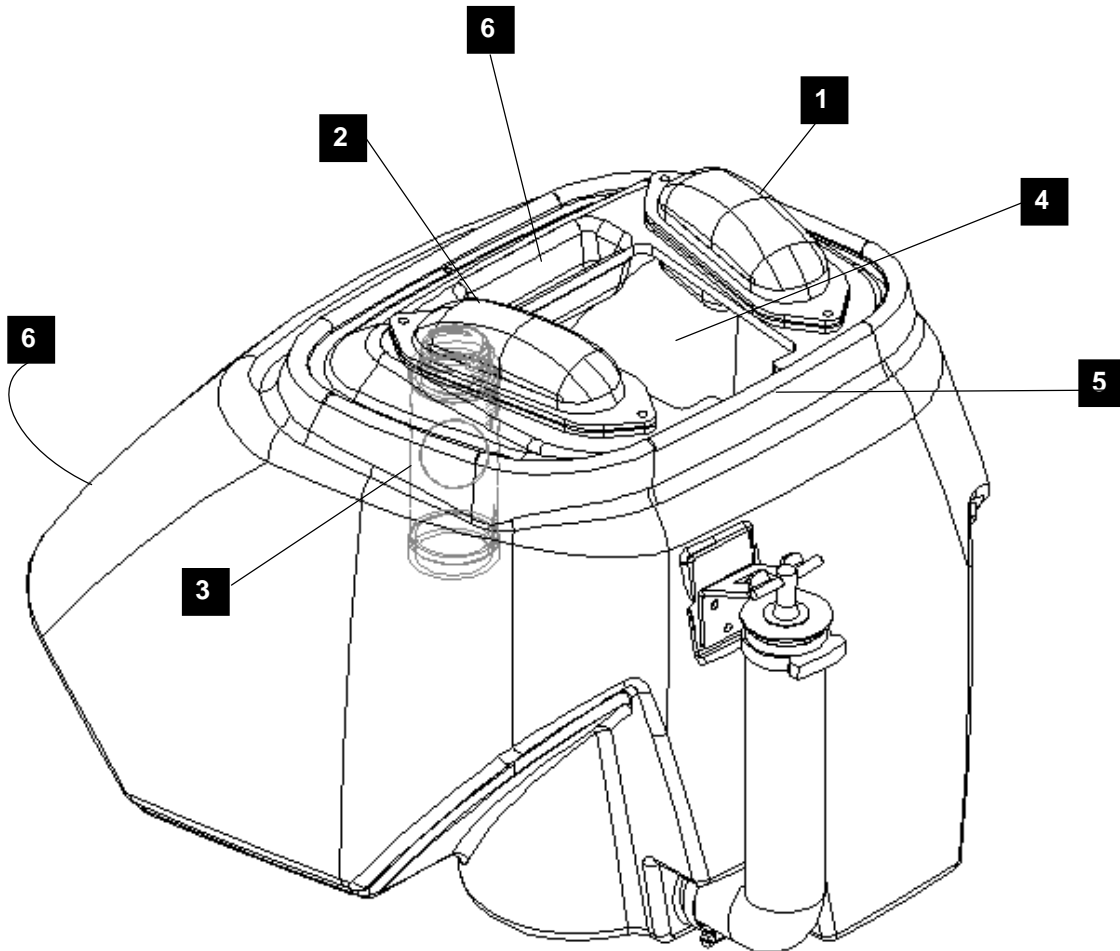

FILLING OPERATIONS

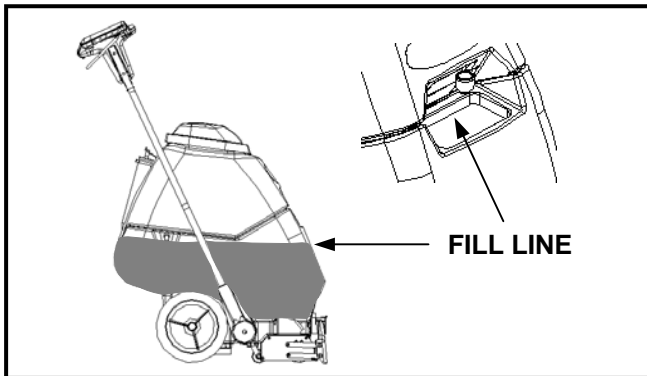
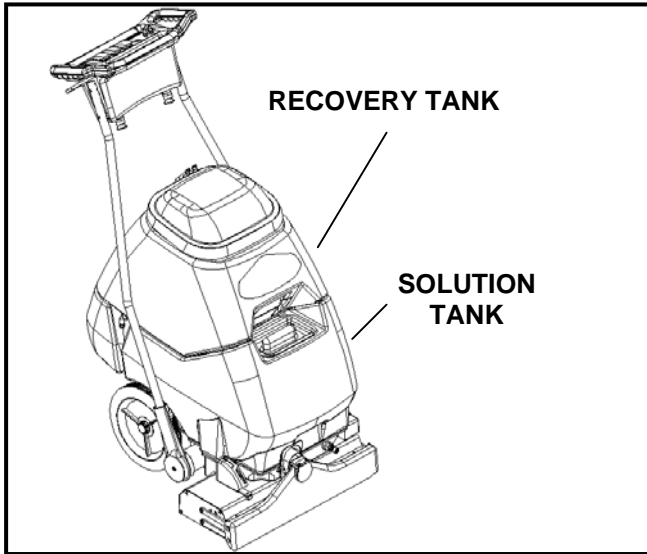

FILLING THE CLIPPER

NOTE: Use clean bucket of water to fill solution tank

Do not put defoamer, solvents, spotter or prespray chemicals in the solution tank.

Do not allow water to spill into vacuum motor inlet. Dry spillage from top of solution tank before replacing recovery tank.

CHEMICALS

Suitable Chemicals

Alkalis
Detergents
Hydroxides
Soaps
Vinegar

Non-Compatible Chemicals

Aldehydes
Aromatic Hydrocarbons
SP Butyls
Carbon Tetrachloride
Clorox*
Chlorinated Bleaches
Chlorinated Hydrocarbons
Lysol*
Methyl Ethel Ketone (MEK)
Perchorethylene (perc)
Phenolics
Trichlorethylene
D-Limonene

STEP
1

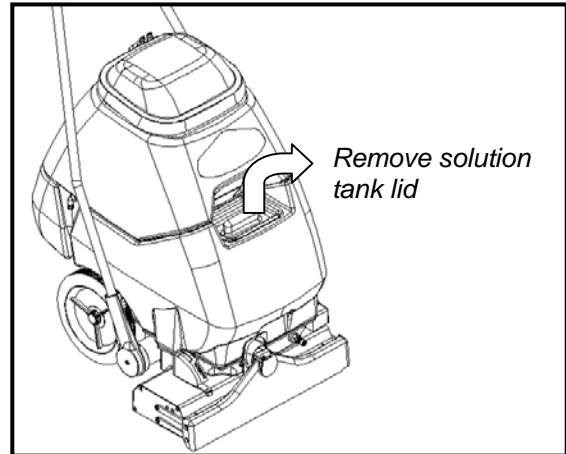

STEP
2

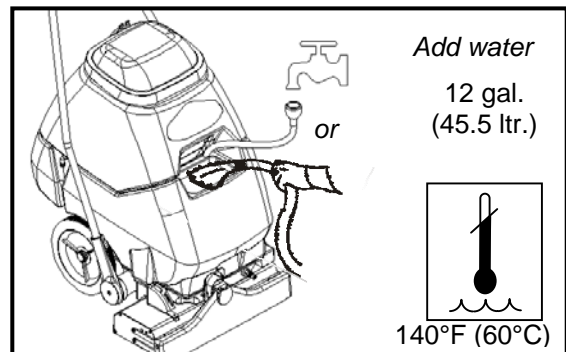

STEP
3

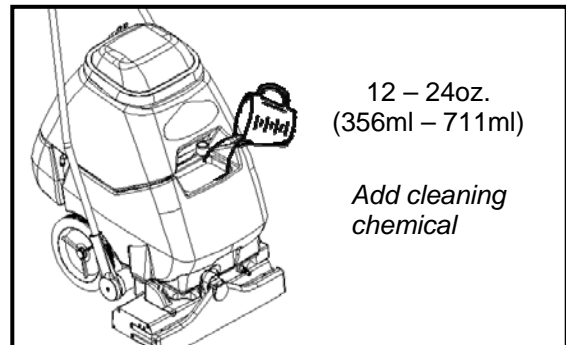

STEP
4

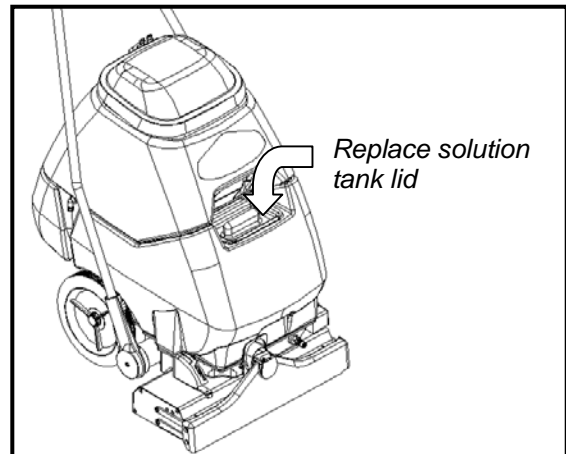

OPERATIONS

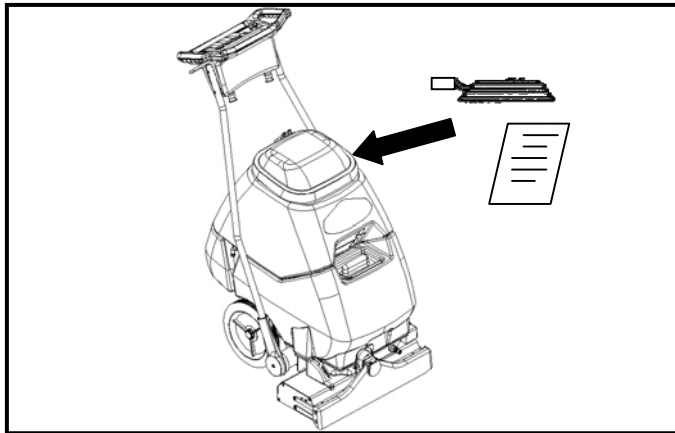

STEP 1 Remove electrical cord and literature from recovery tank. Fill solution tank (see filling instructions page 3-5).

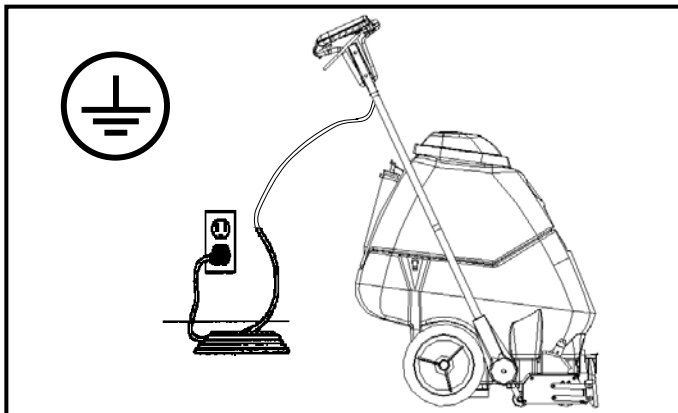

STEP 2 Plug cord into grounded outlet. *Note: Be sure dome is seated on recovery tank, and float shut-off is installed correctly.*

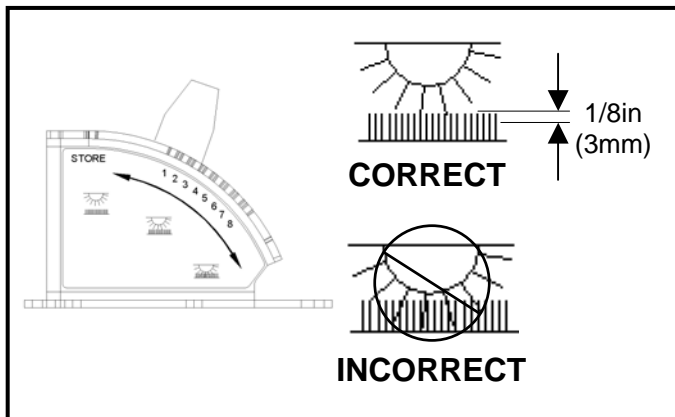

STEP 3 Adjust brush to proper setting. *Note: For good operation the brush must skim the carpet. If circuit breaker trips raise brush to prevent damage to motor or carpet.*

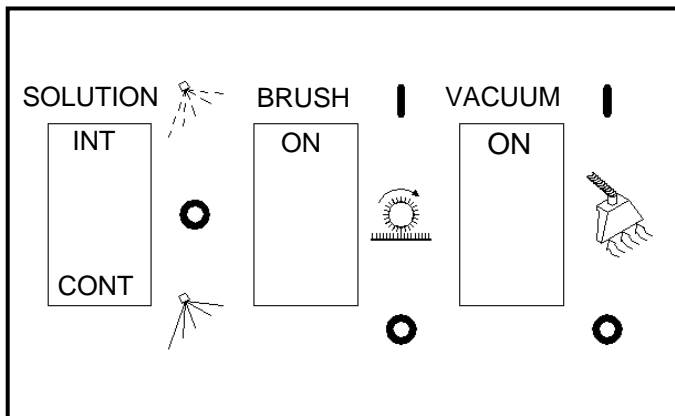

STEP 4 Turn on brush and vacuum motor switches ("ON"="I"). Turn on solution switch for continuous spray or set switch to intermittent to allow use of trigger switches.

OPERATIONS

Adjust handle to comfortable operating position. Tip machine back by main handle to move to starting point.

STEP
5

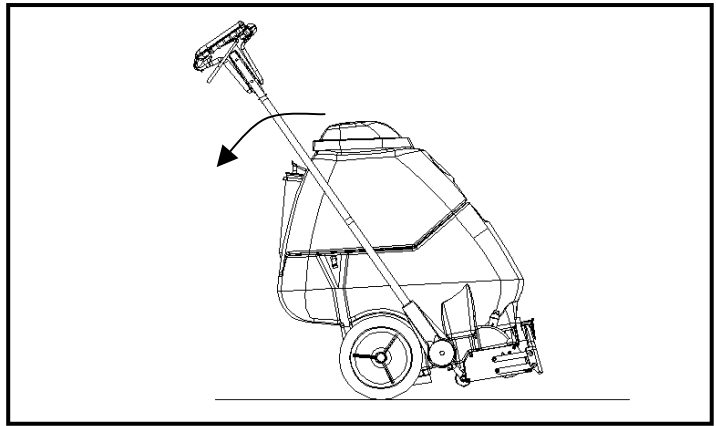

Lower machine to floor.

STEP
6

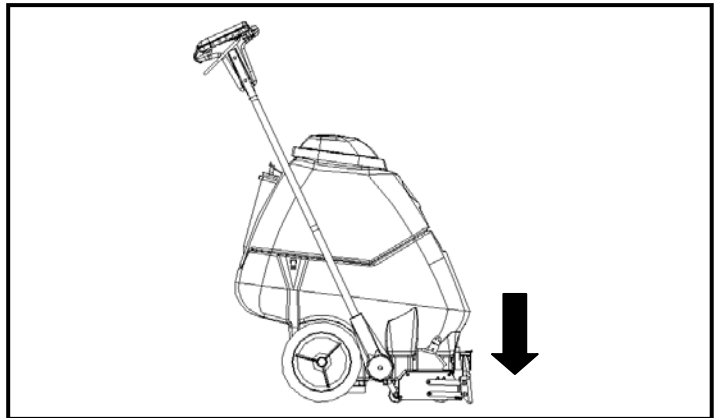

Select continuous setting to start solution spray or select intermittent setting to enable use of trigger switches to start solution spray.

The intermittent setting requires the operator to hold any one of the three trigger switches in the “on” position with the fingers, and is typically used in small areas where short cleaning passes are made. The continuous setting allows the operator to set the switch in the “on” position with one touch, and is typically used in large areas where long cleaning passes are made.

STEP
7

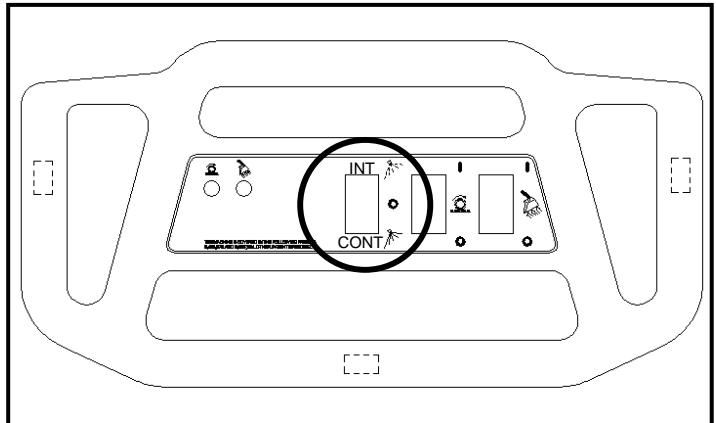

CLEANING PROCEDURE

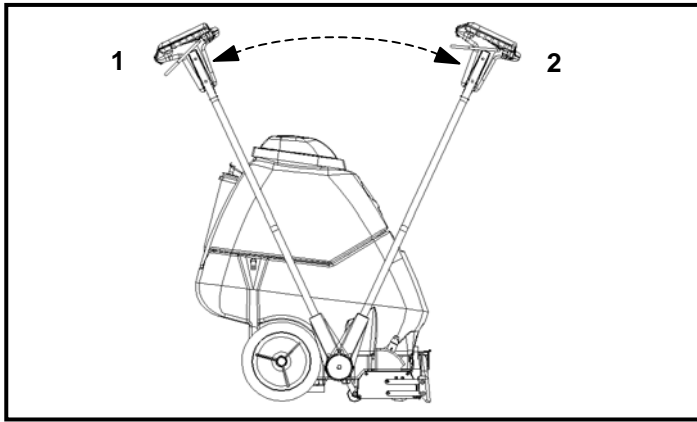

1. This machine can be operated in either direction. For smaller areas operate the machine by pulling rearward.
2. For larger unobstructed areas, flip the handle and use the machine's brush assisted propelling motion.

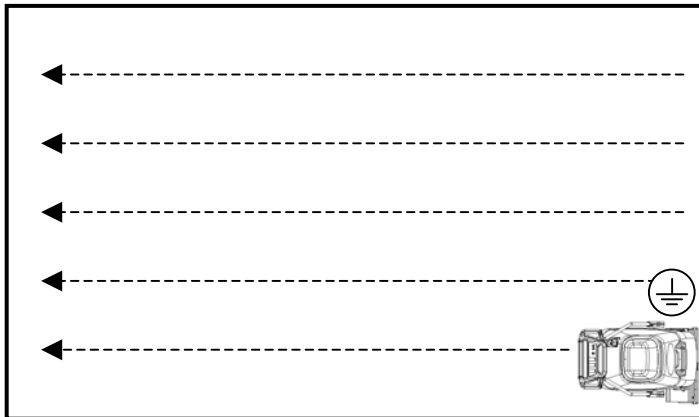

STEP 1

Start at wall closest to power outlet. For small areas, pull straight back without pushing down on handle.

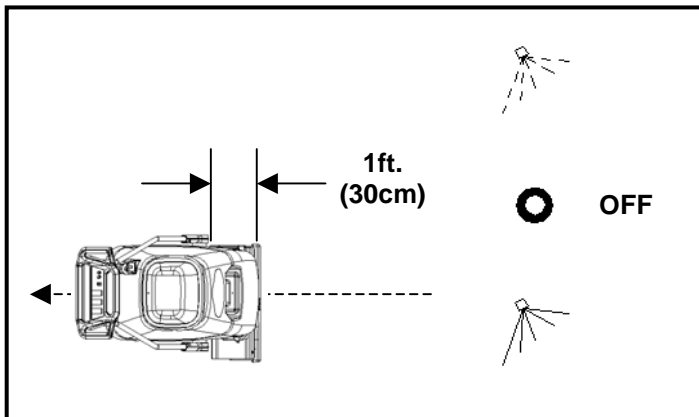

STEP 2

Release intermittent trigger switches or turn off continuous setting on solution switch approximately 1 foot before ending cleaning pass.

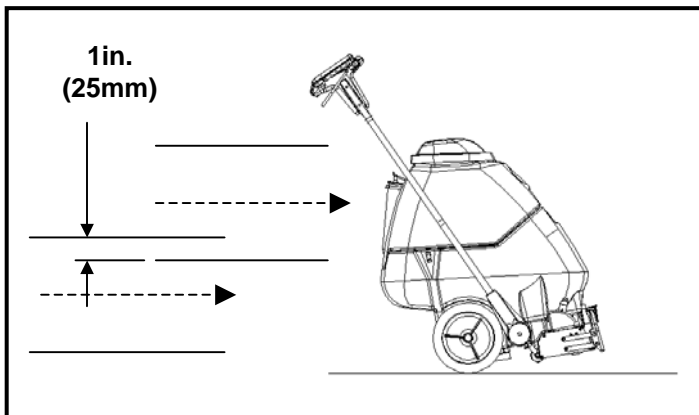

STEP 3

Push down on handle to raise vacuum shoe and brush before moving to the next cleaning pass. Overlap brush contact area approximately 1inch.

CLEANING PROCEDURE

Start at wall closest to power outlet. For large areas flip handle and operate machine in parallel passes, overlapping brush path. Clean perimeter last.

OR

STEP
1

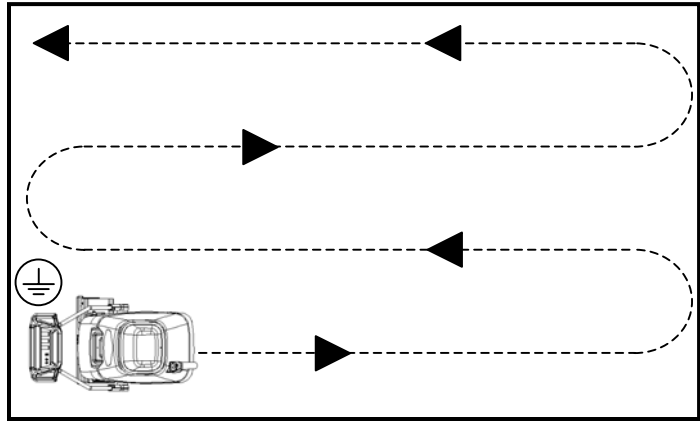

During operation, observe the following: The Clipper is equipped with clear internal covers to facilitate operator viewing of dirty solution and vacuum air flow.

During operation, observe the vacuum intake cover. Large amounts of water or foam entering the vacuum system can damage the vacuum motor. If you notice either condition, **shut down the machine immediately**. Empty recovery tank and/or add defoamer to recovery tank.

STEP
4

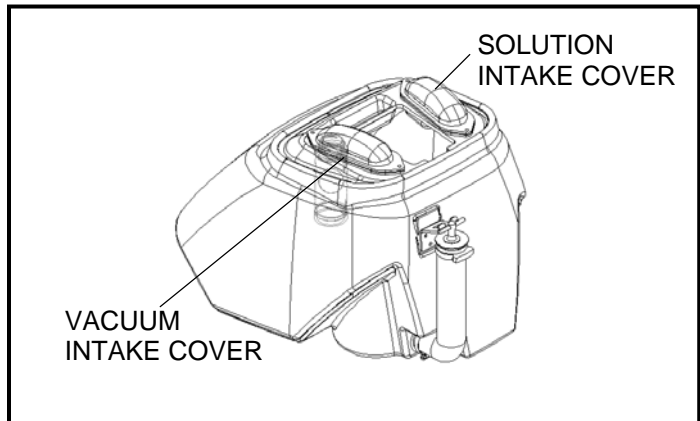

Use right side of machine for cleaning against walls.

STEP
5

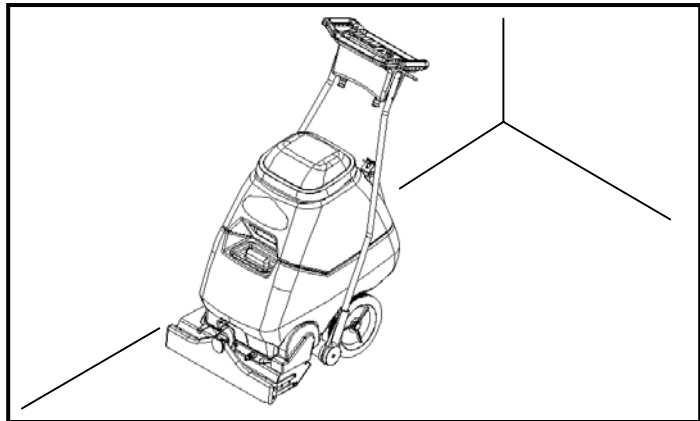

After cleaning, turn off all controls, return brush to storage position and carefully unplug machine.

STEP
6

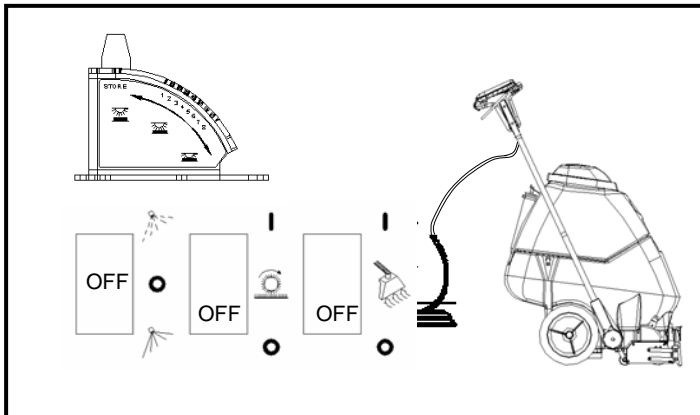

CLEANING PROCEDURE

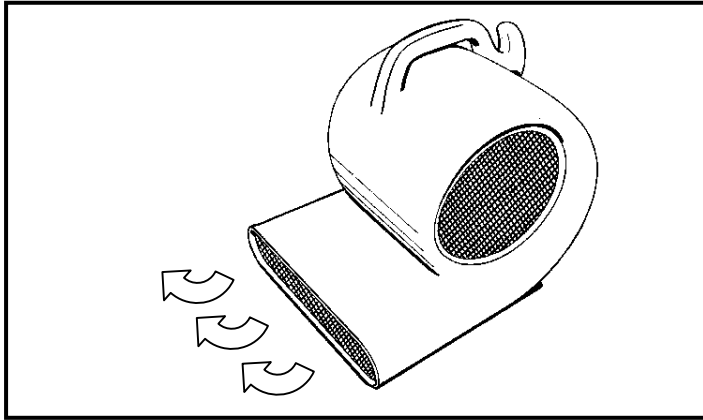

**STEP
7**

To speed drying, use a Windblower™ fan.

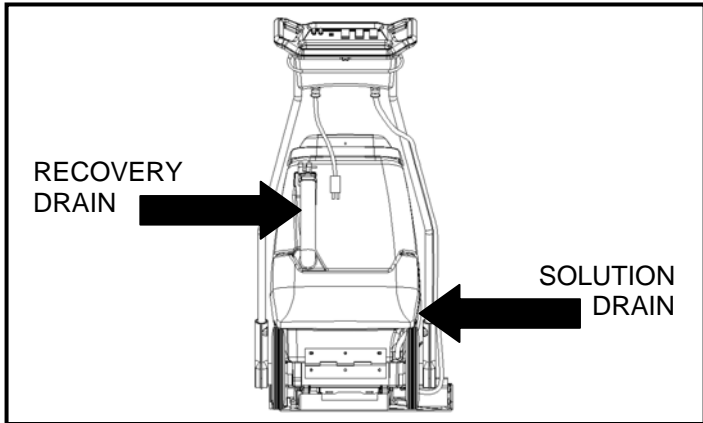

**STEP
8**

Empty recovery tank by releasing dump hose. Use a hose with cold water to clean out the recovery tank. Also drain solution tank after each use.

ACCESSORY TOOL USAGE

Use only one of the following acceptable accessory tools.

HT – 86000610 - PRV NO. 89227
DDH – 86000600 - PRV NO. 89226
DH - 86031540 - PRV NO. 39504

Pull back collar and insert over machine mounted fitting, then release collar to lock into place.

STEP
1

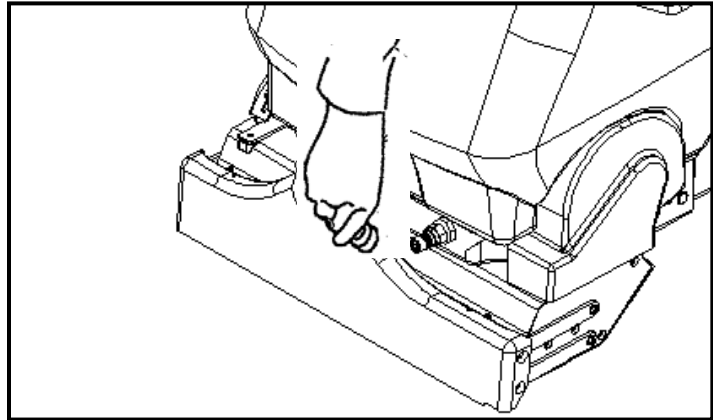

Lift door on front of vacuum shoe and insert 1 ½ inch hose cuff into hole.

STEP
2

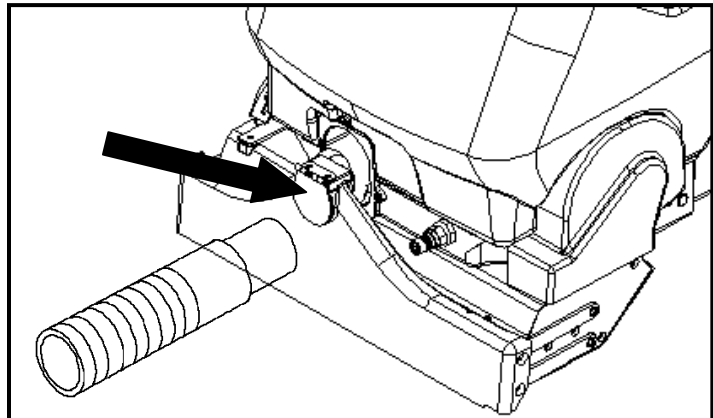

Turn on vacuum motor switch and set solution switch to intermittent position.
Note: Be sure brush switch is in off position and brush is in storage position.

STEP
3

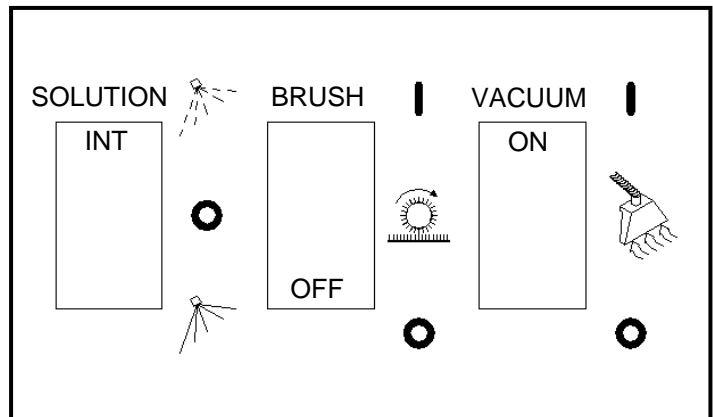

Squeeze handle on accessory tool to begin cleaning.

STEP
4

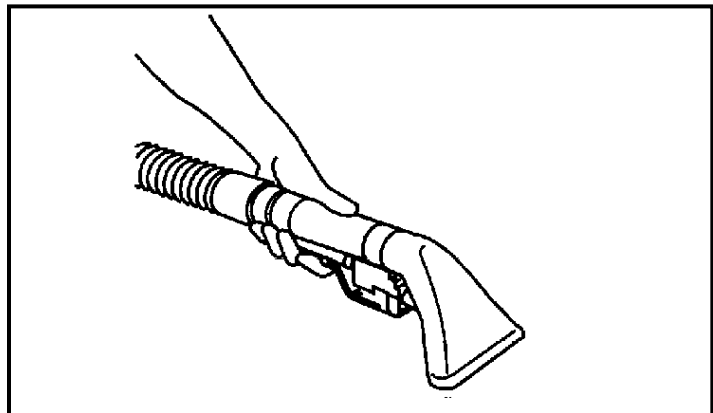

SERVICE SCHEDULE

MAINTENANCE	DAILY	WEEKLY	QUARTERLY
Check machine for cord damage	*		
Check recovery dome and gasket for damage and cleanliness	*		
Check brush – should be clean with no lint or strings attached	*		
Inspect vac shoe for blockage; remove fibers with coat hanger, etc.	*		
Check hoses for wear, blockages, or damage	*		
Check handles, switches, and knobs for damage	*		
Check vac motor intake filter and clean	*		
Run one gallon of water through system	*		
Clean out recovery tank and check float valve to make sure it moves freely	*		
Clean out solution tank and remove and clean vacuum intake screen	*		
Clean outside of all tanks and check for damage	*		
Run vac motor for at least one minute to allow motor to dry	*		
Store with dome off tank to allow the tank to dry	*		
Check all bearings for noise		*	
Check all gaskets for wear and leakage		*	
Check vacuum intake screen for damage; replace if necessary		*	
Check pump pressure; observe spray pattern and check with gauge if necessary		*	
Check and clean solution screen		*	
Check belts for wear and replace as necessary		*	
Check brush for wear; ensure bristles are not damaged		*	
Check cables for fraying		*	
Check the spray bar (manifold) for damage; replace if broken or bent		*	
Check condition of vac shoe and frame for damage		*	
Check overall performance of machine		*	
Check vac motor carbon brushes			*

MAINTENANCE

PERIODIC MAINTENANCE

Twice a month, flush a white vinegar solution (One quart vinegar to two gallons of water) or anti-browning solution (mixed as directed) through the extractor. This will prevent build-up of alkaline residue in the system. If spray jets become clogged, remove the spray tips, wash them thoroughly, and blow-dry.

NOTE: Do not use pins, wire, etc. to clean nozzles as this could destroy spray pattern.

Periodically inspect all hoses, electrical cables and connections on your machine. Frayed or cracked hoses should be repaired or replaced to eliminate vacuum or solution pressure loss. If the cable insulation is broken or frayed, repair or replace it immediately. Don't take chances with electrical fire or shock.

DAILY / REGULAR MAINTENANCE

Before making any adjustments or repairs to the machine, disconnect the power cord from electrical source.

1. Empty unused cleaning solution from the solution tank.
2. Inspect and clean filter screen in solution tank.
3. Flush pumping system with 4 or 7 liters of clean, hot water.
4. After each use, rinse tank with fresh water. Periodically inspect the recovery tank and decontaminate if necessary, using a Hospital Grade Virucide or a 1-10 bleach to water solution. Waste water should be disposed of properly.
5. Check for and remove any lint or debris around vac shoe.
6. Check spray jets for full spray pattern.
7. Remove lint and dirt build-up from brush and housing.
NOTE: Brush removal.
 - A. To remove brush, grab and pull brush out from end opposite drive belt (operator's right). Remove other end from brush driver.
 - B. To install brush, line up slots in brush core with pin in driver on drive belt side (operator's left) and push brush onto driver. Then snap bearing end (opposite end) of brush into retaining clip.
8. Check cooling air screen (located on frame behind left wheel) for lint or debris.
9. Check float and shut-off screen and clean as necessary.

NOTE: Always store machine with brush in "Store" position.



WARNING:

ONLY QUALIFIED MAINTENANCE PERSONNEL ARE TO PERFORM THE FOLLOWING REPAIRS

VACUUM MOTOR REPLACEMENT

1. Turn off all switches and unplug machine.
2. Remove recovery tank.
3. Remove the (2) screws that fasten the solution tank to the frame, and tilt tank back to expose the inside of the frame.
4. Locate the vacuum motor wires and disconnect at the connector. Close the solution tank.
5. Remove the (6) screws holding the vacuum motor cover (p/n 27809) to the solution tank.
6. Remove the vacuum motor.
7. Reverse process to install vacuum motor.

Vacuum Motor Carbon Brushes Replacement (Windsor)

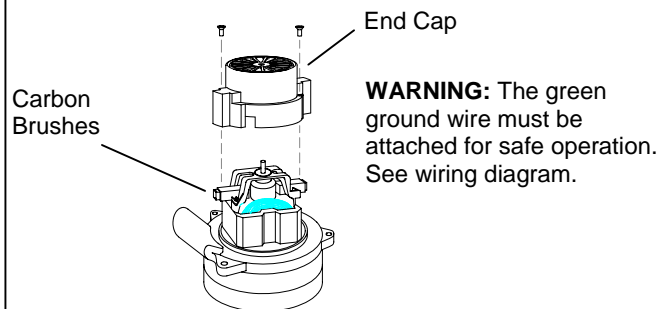

If armature commutator is grooved, extremely pitted or not concentric, the motor will need to be replaced or sent to a qualified service center.

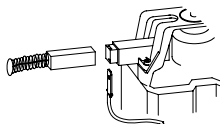

Important:

These brushes wear quicker as the length shortens due to increased heat. Spring inside brush housing will damage motor if brushes are allowed to wear away completely.

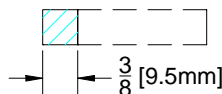

Periodically check the length of the carbon brushes. Replace both carbon brushes when either is less than 3/8" (9.5mm) long.

Vacuum Motor Carbon Brushes Replacement (Ametek)

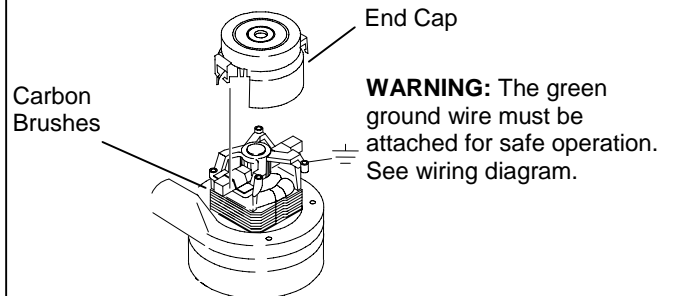

Note: When replacing carbon brushes loosen wire terminal **BEFORE** removing screws on bracket.

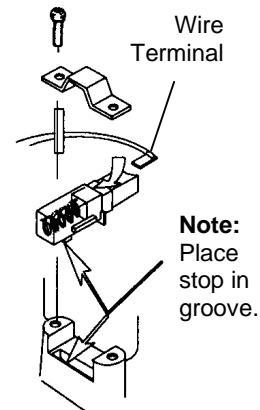

If armature commutator is grooved, extremely pitted or not concentric, the motor will need to be replaced or sent to a qualified service center.

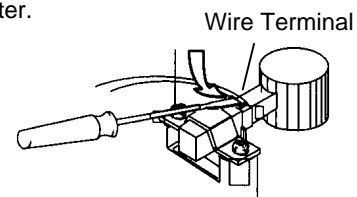

Important:

These brushes wear quicker as the length shortens due to increased heat. Spring inside brush housing will damage motor if brushes are allowed to wear away completely.

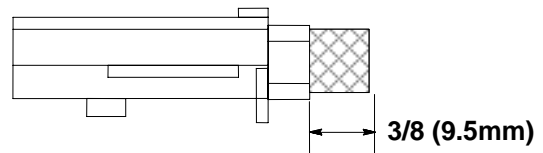

Periodically check the length of the carbon brushes. Replace both carbon brushes when either is less than 3/8" (9.5mm) long.

MAINTENANCE



WARNING:

ONLY QUALIFIED MAINTENANCE PERSONNEL ARE TO PERFORM THE FOLLOWING REPAIRS.

BELT REPLACEMENT

1. Turn off all switches and unplug the machine.
2. Remove recovery tank.
3. Remove the (2) screws that fasten the solution tank to the frame, and tilt tank back to expose the inside of the frame.
4. Remove solution hoses from fittings in pump.
5. Remove the (2) screws that fasten the pump to the frame.
6. Reverse process to install pump.

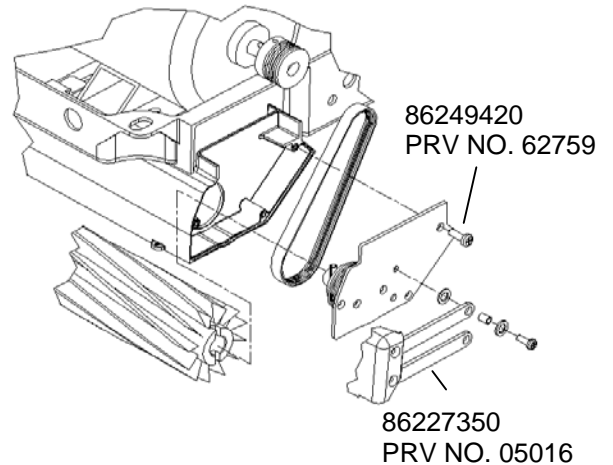



WARNING:

ONLY QUALIFIED MAINTENANCE PERSONNEL ARE TO PERFORM THE FOLLOWING REPAIRS.

SOLUTION PUMP REPLACEMENT

1. Turn off all switches and unplug the machine.
2. Remove recovery tank.
3. Remove the (2) screws that fasten the solution tank to the frame, and tilt tank back to expose the inside of the frame.
4. Remove solution hoses from fittings in pump.
5. Remove the (2) screws that fasten the pump to the frame.
6. Reverse process to install pump.

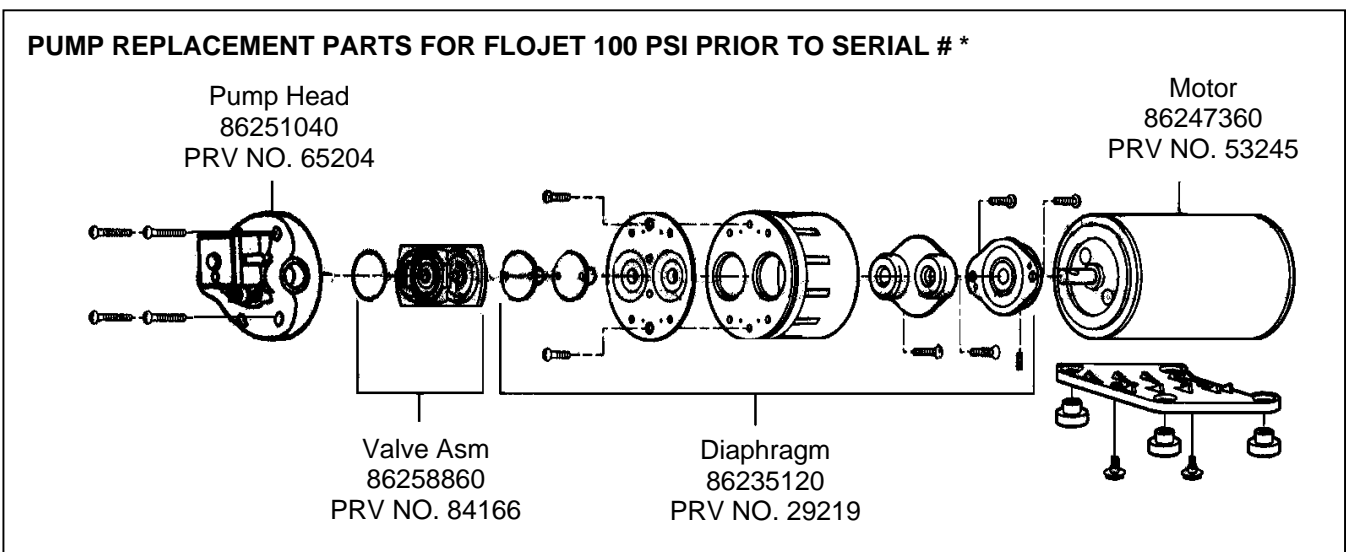
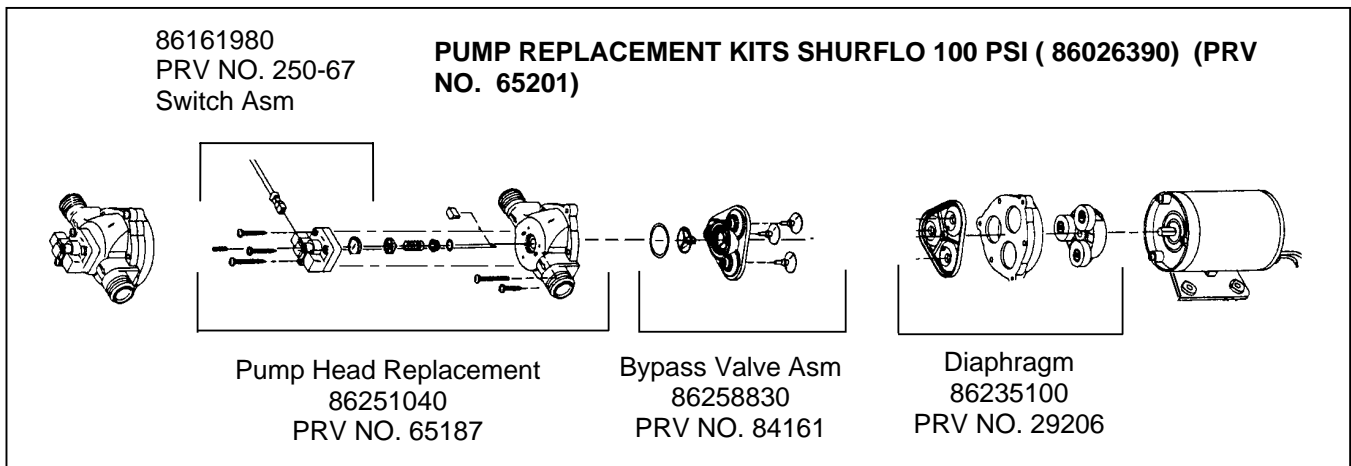

WIRING DIAGRAM

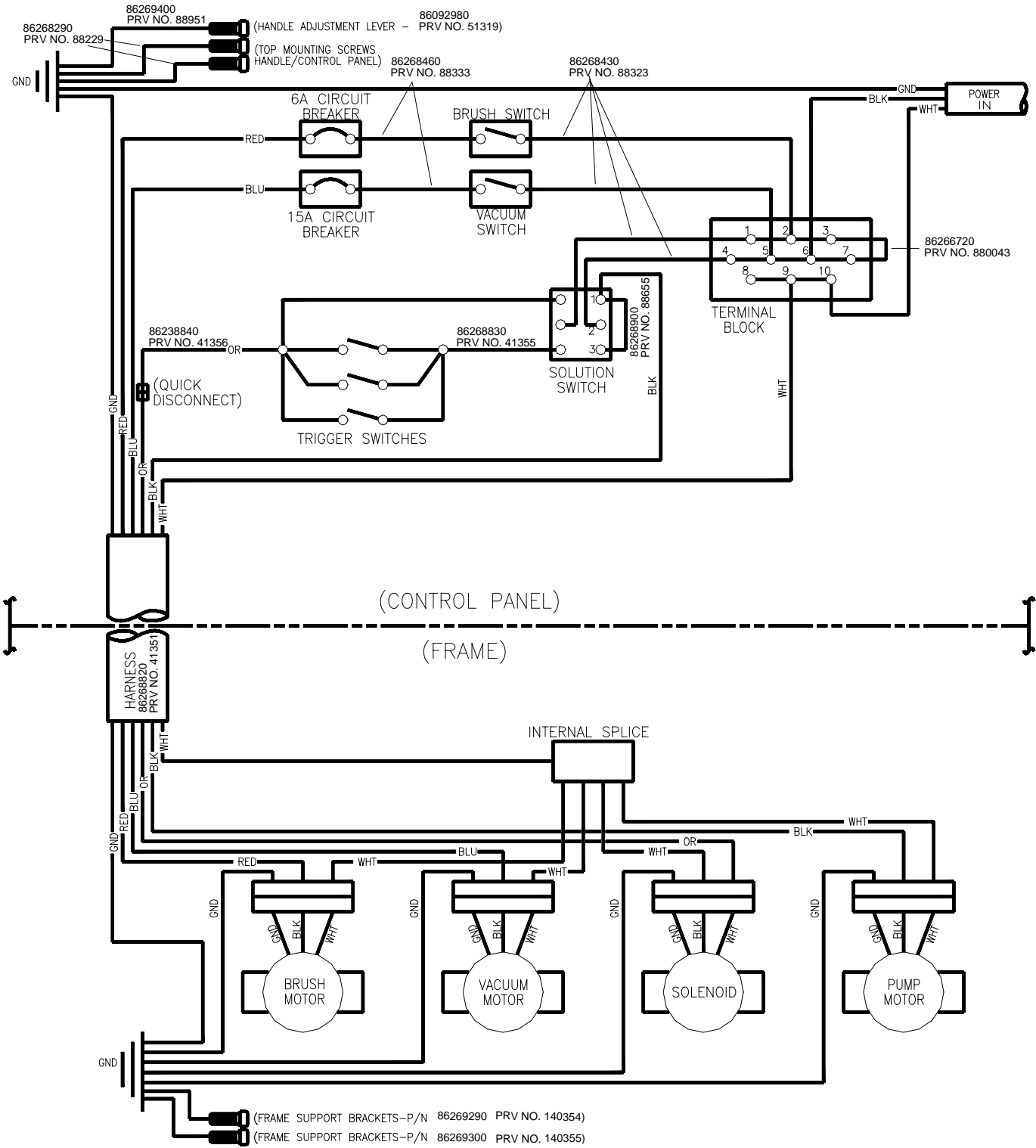

TROUBLESHOOTING CHART

PROBLEM	CAUSE	SOLUTION
No Power, Nothing Runs	Is the cord plugged in.	Plug in cord.
	Circuit breaker tripped in building.	Reset breaker.
	Faulty switch.	Call for service.
	Faulty power cord or pigtail.	Call for service.
Vacuum Motor Will Not Run	Vacuum circuit breaker tripped.	Reset breaker.
	Faulty main vacuum switch.	Call for service.
	Loose wiring.	Call for service.
	Faulty vac motor.	Call for service.
Vacuum Motor Runs But Suction Is Poor	Debris lodged in vac shoe.	Remove debris from vac shoe.
	Dome gasket defective or missing.	Replace as necessary.
	Vacuum hose cracked or hose cuff loose.	Replace or repair as necessary.
	Recovery tank full / float ball stuck in the up position.	Turn off vac motor. Drain and rinse recovery tank.
Poor Or No Water Flow (Carpet Is Streaky)	Main pump switch off.	Turn on.
	Jets clogged or missing.	Clean using a vinegar /water solution or replace.
	Solution filter clogged.	Drain solution tank and clean solution filter.
	Faulty solenoid.	Call for service.
Brush Does Not Spin	Brush switch off.	Turn on brush switch.
	Brush circuit breaker tripped.	Reset circuit breaker.
	Brush belt broken.	Replace as necessary.
	Faulty brush motor.	Call for service.

FRAME ASSEMBLY

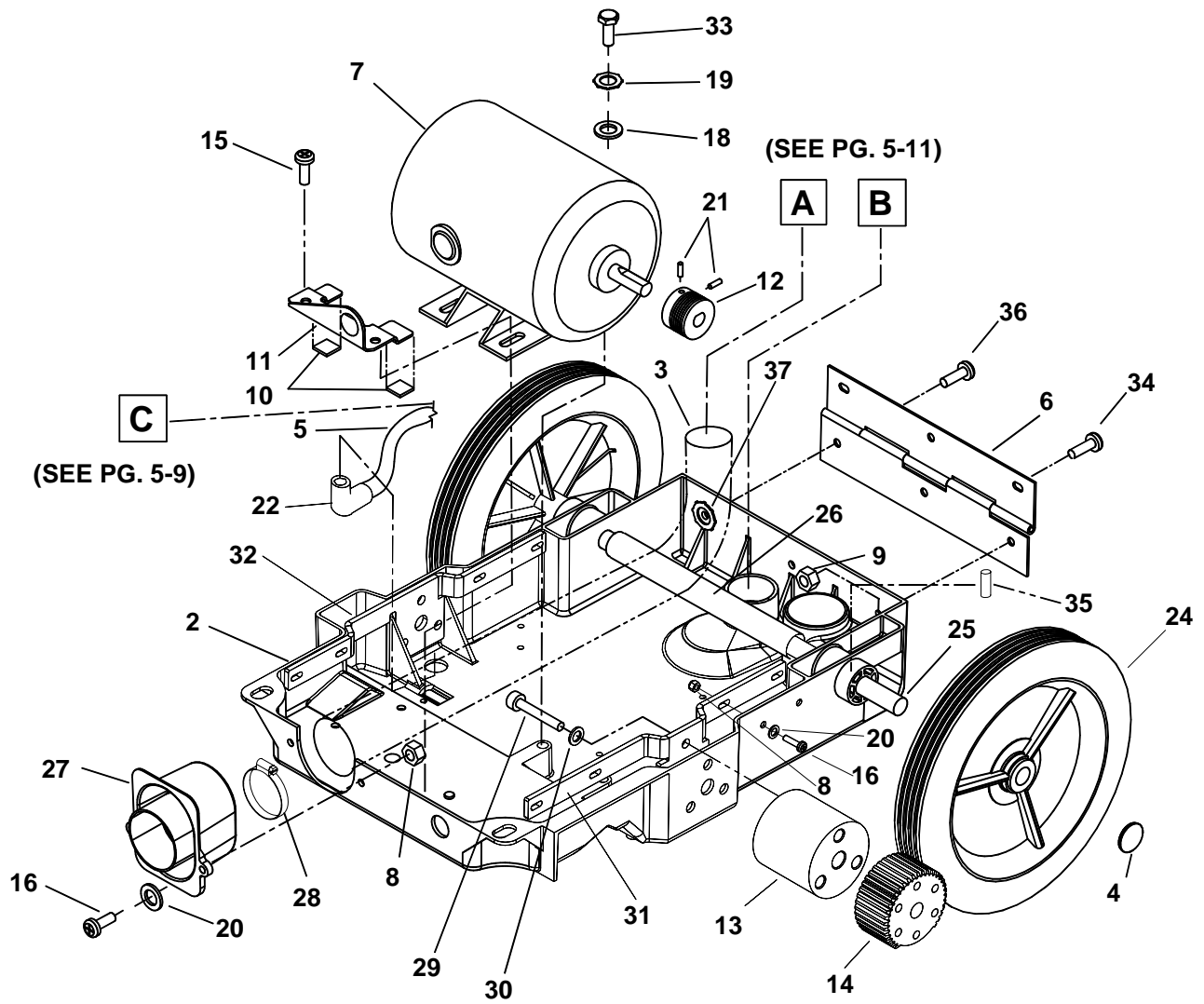

FRAME ASSEMBLY

REF	PART NO.	PRV NO.	QTY	DESCRIPTION	SERIAL NO. FROM	NOTES:
1		OPEN				
2	86033080	34357	1	FRAME, CLIPPER 12		
3	86004340	39528	1	HOSE ASM, 1.5 BLK VAC X 15.5		
4	86001660	41236	2	HUBCAP, 5/8" SHAFT		
5	86238820	41351	1	HARNESS, MAIN, CLP/ADM		
6	86239610	41354	1	HINGE, TANK TO FRAME		
7	86026150	53640	1	MOTOR ASM, BRUSH CLP FAMILY		
8	86005640	57030	10	NUT, 10-32 HEX NYLOCK		
9	86005810	57245	3	NUT, 1/4-20 HEX NYLOCK SS		
10	86198530	99809	2	FOAM TAPE, 1/8 THK X 3/4 1SDA		
11	86249430	62761	1	PLATE, BRUSH MTR CLAMP		
12	86006020	64099	1	PULLEY, 1.4 OD, 6GR, MICRO-V		
13	86254480	73949	2	SPACER, HANDLE PIVOT		
14	86109940	36081	2	GEAR, 40 TOOTH		
15	86002730	70085	2	SCR, 1/4-20 X 1/2 PPHMS SS		
16	86022200	70066	10	SCR, 10-32 X 3/4 PPHMS		
17		OPEN				
18	86010630	87013	2	WASHER, 1/4 ID X 5/8 OD SS		
19	86010660	87025	2	WASHER, 1/4 LOCK EXT STAR SS		
20	86010650	87018	10	WASHER, #10 X 9/16 OD		
21	86019800	70074	2	SET SCR, 10-32 X 1/4 KCP		
22	86256190	73197	1	STRAIN RELIEF, 90 DEGREE		
23		OPEN				
24	86259960	89506	2	WHEEL, 1-15/16 X 10" HOOSIER		
25	86066230	03107	1	AXLE, 5/8 X 17.06L		
26	86134490	99667	10"	HEAT SHRINK, 3/4 ID UL/CSA		
27	86253090	73943	1	SEAL, FRAME/TANK		
28	86222760	20041	1	CLAMP, 2.0" WORM GEAR		
29	86276500	70671	6	SCR, 5/16-18 X 3.5 SHCS PLATED		
30	86279130	87083	6	WASHER, 5/16 SPLIT LOCK PLTD		
31	86069290	140354	1	BRKT, CLP HANDLE SUPPORT		
32	86069300	140355	1	BRKT, CLP HANDLE SUPPORT LT		
33	86274760	70271	2	SCR, 1/4-20 X 1/2 HHCS PLTD		
34	86006530	70057	2	SCR, 1/4-20 X 1 PPHMS SS		
35	86272160	66052	1	PIN, ROLL 1/8" X 1.0"L		
36	86276610	70697	1	SCR, 1/4-20 X 1.25 PPHMS SS		
37	86005710	57105	3	NUT, 1/4-20 HEX W/ STAR WASHER		

BRUSH ASSEMBLY

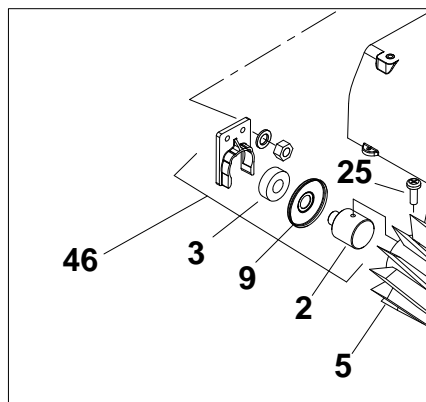
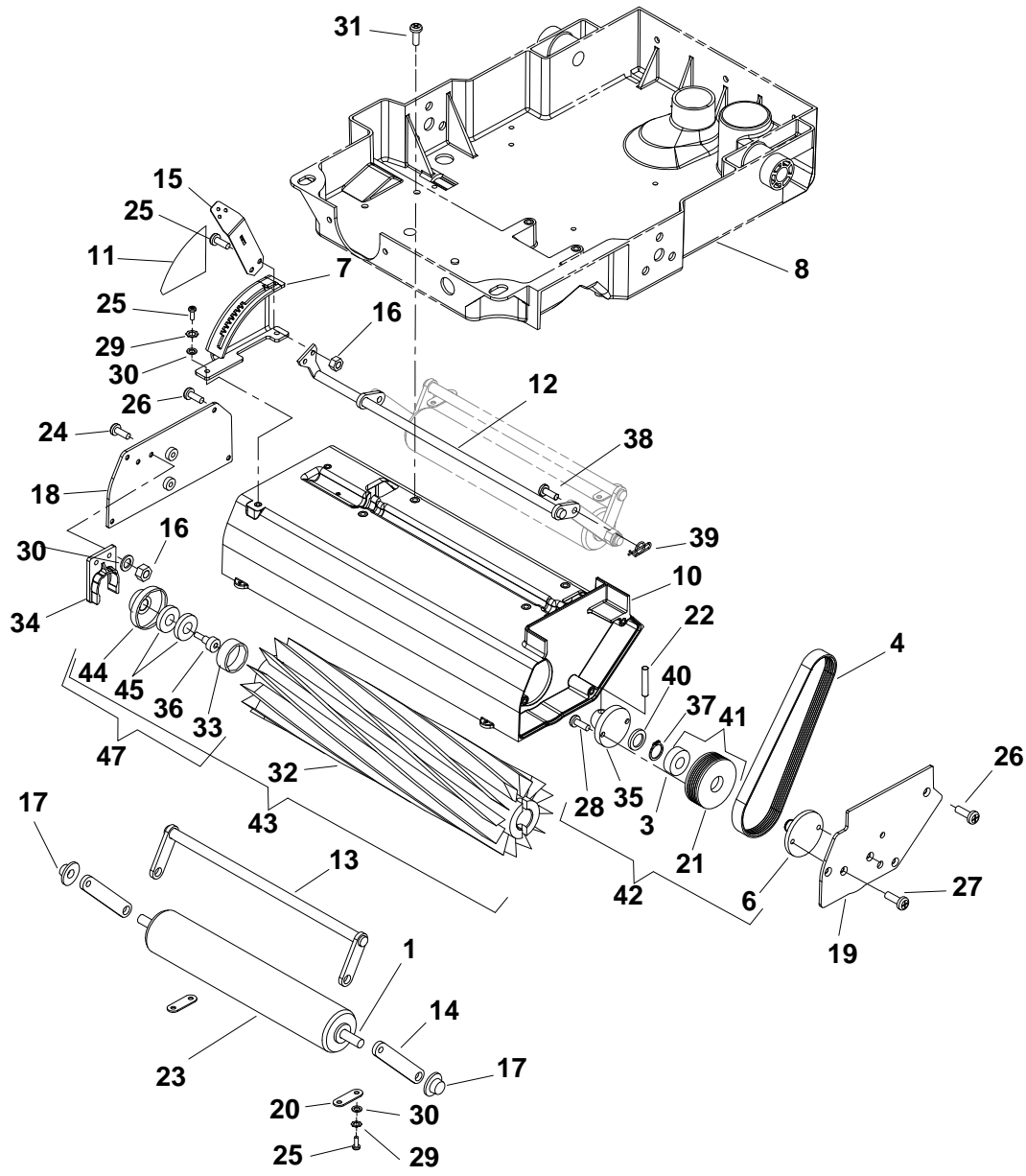

BRUSH ASSEMBLY

REF	PART NO.	PRV NO.	QTY	DESCRIPTION	SERIAL NO. FROM	NOTES:
1	86053690	03110	1	AXLE, ROLLER		
2	86227100	04084	1	ADAPTER, BRUSH BRG.		
3	86000900	09019	2	BEARING, 1.125ODX.500IDX.375		
4	86001100	11045	1	BELT, 180J6 MICRO-V		
5	86001150	12515	1	BRUSH, 18L X 3.38OD		WAS 12032
6	86001300	140343	1	BRKT, BRUSH PULLEY		
7	86001310	140351	1	BRKT, BRUSH HEIGHT		
8	86033080	34357	REF	FRAME, CLIPPER 12		
9	86103150	36192	2	GUARD, THREAD		
10	86240970	41346	1	HOUSING, BRUSH, 18"		
11	86004980	50998	1	LABEL, BRUSH HEIGHT		
12	86093080	51311	1	LINKAGE, ASM, BRUSH HEIGHT		
13	86126540	51312	1	LINKAGE ASM, ROLLER SUPPORT		
14	86264660	51314	2	LINK, ROLLER, FRONT		
15	86005130	51317	1	LEVER, HEIGHT ADJUSTMENT		
16	86005640	57030	4	NUT, 10-32 HEX NYLOCK		
17	86005850	57271	2	NUT, 3/8 DIA CAP, TYPE PUSH PLT		
18	86249410	62758	1	PLATE, BRUSH HOUSING RH		
19	86249420	62759	1	PLATE, BRUSH HOUSING LH		
20	86264700	62762	2	PLATE, AXLE RETAINER		
21	86114410	64098	1	PULLEY, 2.2 OD, 6GR, MICRO-V		
22	86006220	66192	1	PIN, ROLL 1/4 X 1.25L		
23	86006430	67411	1	ROLLER, 1.9 DIA X 10.5 LG		
24	86006510	70043	2	SCR, 10-32 X 5/8 PPHMS		
25	86006590	70088	6	SCR, 10-32 X 1/2 PPHMS SS DL		
26	86006650	70177	7	SCR, 10-32 X 1/2 FHMS SS		
27	86006700	70232	2	SCR, 10-32 X 3/8 FHMS SS		
28	86275530	70497	2	SCR, #10-24 X 1/2 SHCS		
29	86010640	87016	4	WASHER, #10 LOCK EXT STAR SS		
30	86010650	87018	6	WASHER, #10 X 9/16 OD		
31	86203850	70675	4	SCR, 1/4-20 X. 5/8 THMS PLTD NP		
32	86230630	12525	1	BRUSH, 18L X 3.38 OD G2	1000090717	
33	86251710	67467	1	RING, TOLERANCE 7/8 ID X 1/2 W	1000090717	
34	86003070	27805	1	CLIP, BEARING		
35	86003370	29157	1	DRIVER, BRUSH		
36	86202450	70737	1	SHLDR BOLT, 3/8 OD X 3/8 L SS NP	1000090717	
37	86272770	67094	1	RING, 1/2 EXT. SNAP		
38	86272510	66310	2	PIN, CLEVIS 1/4 X 1/2 PLTD		
39	86008650	80604	2	COTTER, 1/4" RING		
40	86008160	73966	1	SPACER, .81ID X 1.06OD, ALUM		
41	86006030	64102	1	PULLEY ASM, BRUSH		
42	86003390	29208	1	DRIVER ASM, BRUSH		
43	86001150	12515	1	BRUSH ASM, 18 IN		
44	86227150	05158	1	ADAPTER, BRUSH BRG. DIE CAST	1000090717	
45	86228890	09137	2	BEARING, R6 3/8 ID	1000090717	
46	86028010	47383	1	BRUSH BEARING ASM.		
47	86004750	47416	REF	KIT,BRNG/ADPTR EXTRCTR		

PUMP ASSEMBLY

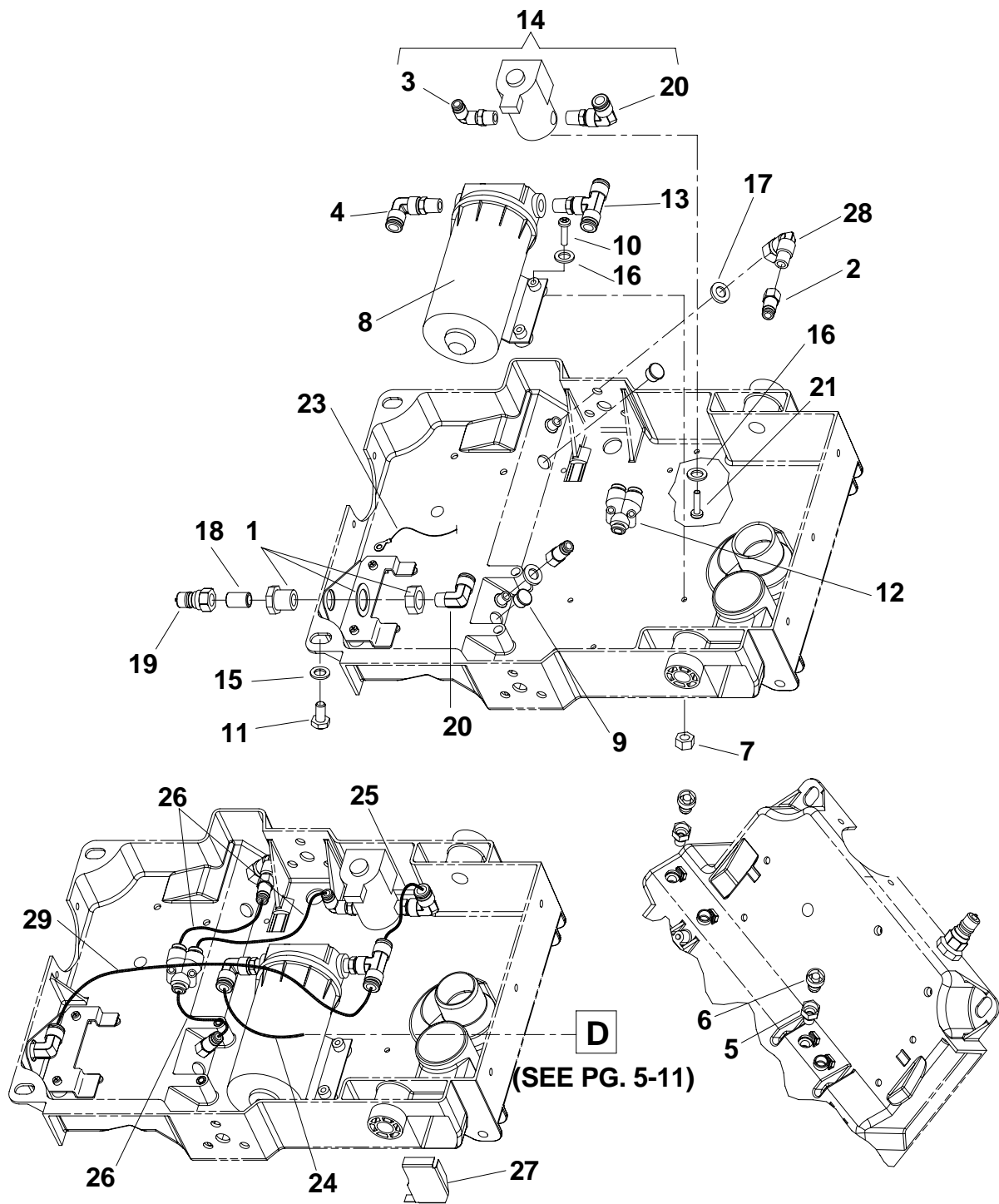

PUMP ASSEMBLY

REF	PART NO.	PRV NO.	QTY	DESCRIPTION	SERIAL NO. FROM	NOTES:
1	86002470	22072	1	COUPLING, 1/4 ANCHOR W/1" HEX		
2	86002480	22090	2	CONNECTOR, 1/8FPT X 1/4 TUBEQC		
3	86003470	31072	1	ELBOW, SWIVEL, 1/4MPTX1/4TUBE		
4	86003490	31074	1	ELBOW, SWIVEL, 3/8MPTX3/8TUBEQC		
5	86004570	44067	2	JET BODY, MINI PROMAX BODY		
6	86004580	44068	2	JET, MINI PROMAX 9504		
7	86005640	57030	2	NUT, 10-32 HEX NYLOCK		
8	86026390	65201	1	PUMP ASM, 115V 100 PSI W/CONN	1000167303	
9	86250140	66288	2	PLUG, 9/16 OD BLK NYLON		
10	86274410	70195	2	SCR, 10-32 X 1.25 PPHMS		
11	86020270	70011	2	SCR, 1/4-20 X 5/8 HHCS SS		
12	86003640	34355	1	FITTING, 1/4 TUBE,"Y", QC		
13	86008360	78419	1	TEE, 3/8 MPT X 3/8 TUBE, QC		
14	86026940	84160	1	VALVE ASM, SOLENOID CLP FAMILY		
15	86010810	87191	2	WASHER, 1/4"IDX1.0OD. FLAT SS		
16	86010650	87018	4	WASHER, #10 X 9/16 OD		
17	86010820	87192	2	WASHER, 7/16 X 3/4 X .19RUBBER		
18	86005590	56014	1	NIPPLE, 1/4 CLOSE		
19	86005580	56012	1	NIPPLE, 1/4 FPT QD		
20	86003500	31076	2	ELBOW, 1/4 MPT X 3/8 TUBE, QC		
21	86210210	70162	2	SCR, 10-32 X 3/8 PPHMS SS		
22		-	-	OPEN		
23	86267400	880278	1	WIRE, 22" GRN/18 76011 X 76011		
24	86281890	39529	1	HOSE, 3/8 URETHANE X 29"		
25	86004350	39530	1	HOSE, 3/8 NYLON X 6"		
26	86281900	39531	3	HOSE, 1/4 URETHANE X 6"		
27	86121350	73963	1	SCREEN, INTAKE		
28	86197400	31022	1	ELBOW, 1/8NPT STREET		
29	86004400	39591	1	HOSE, 3/8 ID NYL11 YLW X 29"		

VACUUM SHOE ASSEMBLY

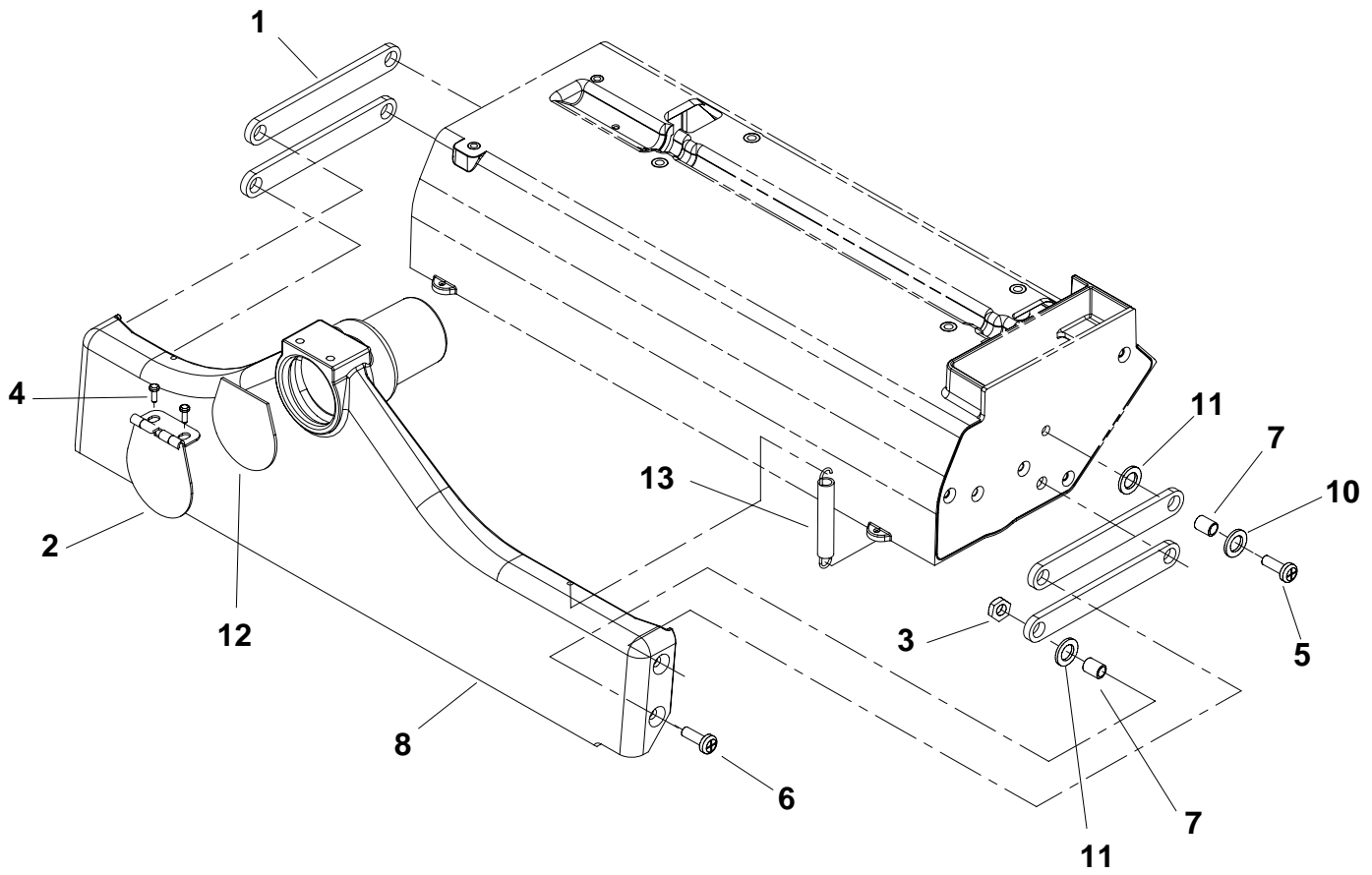

VACUUM SHOE ASSEMBLY

REF	PART NO.	PRV NO.	QTY	DESCRIPTION	SERIAL NO. FROM	NOTES:
1	86227350	05016	4	ARM, VAC SHOE PARALLEL		
2	86234760	27674	1	COVER, ACCESSORY PORT		
3	86005810	57245	4	NUT, 1/4-20 HEX NYLOCK SS		
4	86006790	70351	2	SCR, 10-32 X 3/8 HHTR W/STAR		
5	86210470	70360	4	SCR, 1/4-20 X.75 PPHMS PHIL		
6	86006840	70390	4	SCR, 1/4-20 X 1 FHCS PLTD		
7	86008130	73958	8	SPACER, 3/8ODX.058WX.2814,CRS		
8	86258630	85040	1	VAC SHOE, 18"		
9		OPEN				
10	86010630	87013	4	WASHER, 1/4 ID X 5/8 OD SS		
11	86010700	87074	8	WASHER, WAVE 3/8ID X3/4D X.125		
12	86003780	35171	1	GASKET, ACCESSORY PORT		
13	86008120	73955	2	SPRING, EXT .38D X2.75L X.055W		

CONTROL PANEL ASSEMBLY

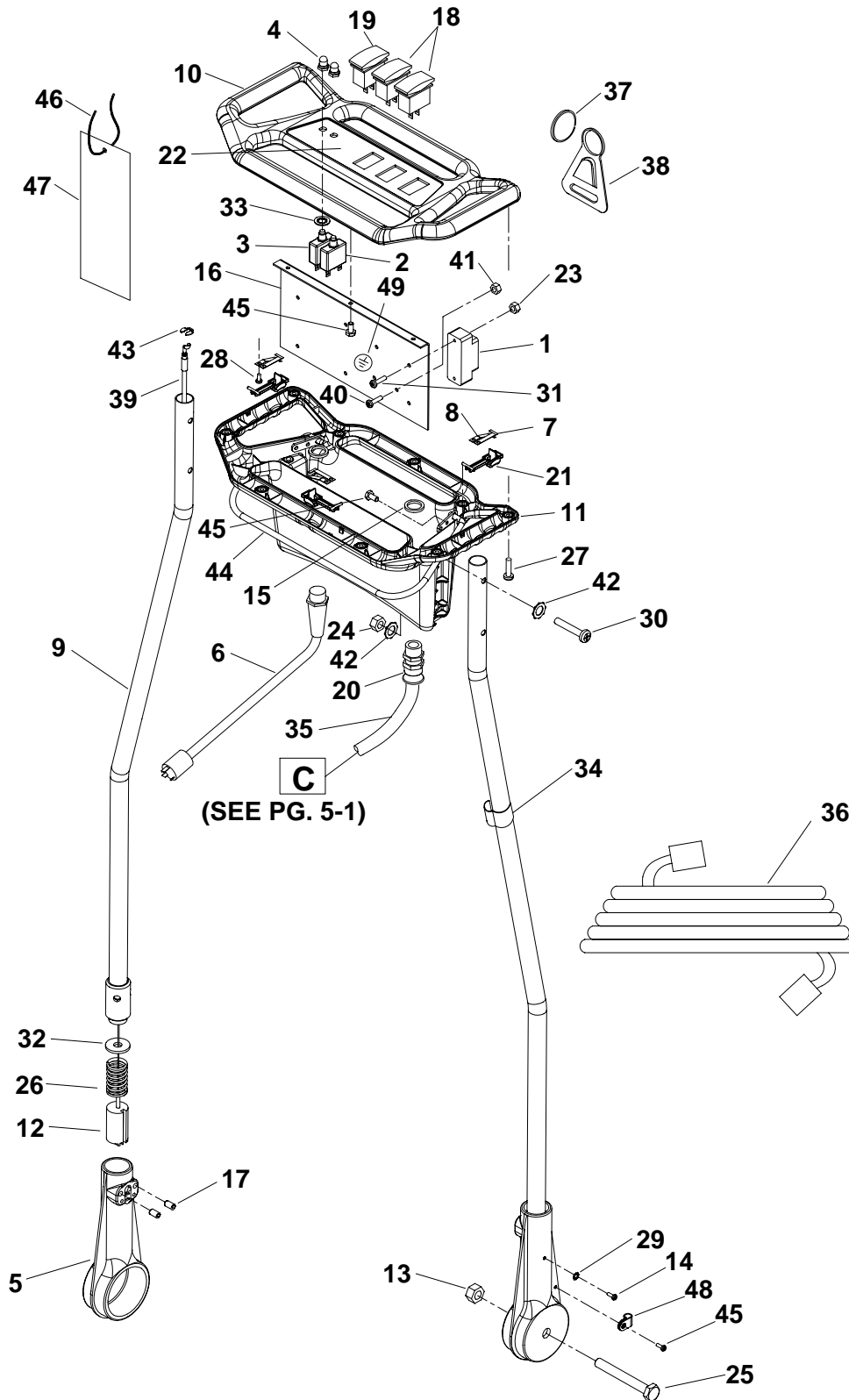

CONTROL PANEL ASSEMBLY

REF	PART NO.	PRV NO.	QTY	DESCRIPTION	SERIAL NO. FROM	NOTES:
1	86001240	14020	1	TERMINAL BLOCK, 115V (3-4-3)		
2	86001980	14700	1	BREAKER, 15A 250VAC 50VDC		
3	86230210	14832	1	BREAKER, 6A VDE CIRCUIT		
4	86002010	14942	2	BOOT, 3/8 CIRCUIT BREAKER		
5	86240890	41181	2	HOUSING, CLP HANDLE PIVOT		
6	86234320	23679	1	CORD ASM, 14/3 X 22" YLW		
7	86003130	27823	3	CONTACT, ELECTRICAL, FLAT		
8	86003140	27824	3	CONTACT, ELECTRICAL, BENT		
9	86004090	38285	2	HANDLE, CLP12 WELDED		
10	86004100	38286	1	HANDLE, CONTROL PANEL FRONT		
11	86004110	38287	1	HANDLE, CONTROL PANEL REAR		
12	86005010	51114	2	LOCK, HANDLE POSITION		
13	86005790	57153	2	NUT, 1/2-13HEXNYLOCK THIN PLTD		
14	86022210	70067	2	SCR, 6-32 X 3/8 PPHMS		
15	86005670	57040	2	NUT, 1/2 NPT CONDUIT		
16	86081530	62766	1	PLATE, CONTROL PANEL, CLP/ADM		
17	86277980	70330	4	SET SCR, 5/16-18 X 1/2 CONE PT		
18	86007140	72130	2	SWITCH, SPST 2-POSITION ROCKER		
19	86007200	72162	1	SWITCH, DPDT3-POSITION ROCKER		
20	86256240	73505	1	STRAIN RELIEF, 1/2 NPT TRUMPET		
21	86008350	78418	3	TRIGGER, SWITCH		
22	86245950	50996	1	LABEL, CONTROL PANEL, CLP/ADM		
23	86005760	57116	2	NUT, 6-32 W/STAR WASHER PLTD		
24	86005810	57245	4	NUT, 1/4-20 HEX NYLOCK SS		
25	86276510	70672	2	SCR, 1/2-13 X 4.75HHCS GR5 PLT		
26	86226840	73307	2	SPRING, COMP .88D X1.4L X.100W		
27	86006870	70406	9	SCR, #10 X 3/4 PPHST TYPE B		
28	86232950	70127	6	SCR, 6-32 X 1/4 PPHMS SS		
29	86279020	87026	2	WASHER, #6 LOCK EXT STAR SS		
30	86231570	70105	4	SCR, 1/4-20 X 1.75 PPHMS SS		
31	86006710	70235	2	SCR, 6-32 X 1.0 PH BLK NYLON		
32	86010720	87086	2	WASHER, M10 X 30 PLTD		
33	86010750	87100	2	WASHER, 3/8 ID INT.LOCK THIN		
34	86198480	27371	2	CLIP, POWER CORD		
35	86238820	41351	REF	HARNESS, MAIN CLP/ADM		
36	86234110	23086	1	CORD SET, 14/3 SJTW-A X 50' YLW		
37	86272840	67147	1	RING, 2" DIA SPLIT		
38	86256170	73169	1	STRAIN RELIEF, CORD HOOK		
39	86003120	27817	2	CABLE, .06 X 40, 0707, SS		
40	86006830	70386	1	SCR, 10-32 X 1" PPHMS		
41	86005700	57104	3	NUT, 10-32 W/STAR WASHER PLTD		
42	86010660	87025	6	WASHER, 1/4 LOCK EXT STAR SS		
43	86006410	67381	2	RING, 1/4 KLIP		
44	86092980	51319	1	LEVER ASM, CLP HANDLE ADJ		
45	86006790	70351	5	SCR, 10-32 X 3/8 HHTR W/STAR		
46	86002870	27417	1	CORD, 99807 1/8 X 12"		
47	86232300	500018	1	CARD, INSTRUCTION CLP12		
48	86002370	20035	1	CLAMP, 7/16 DIA NYLON UL		
49	86245040	50279	1	LABEL, GROUND SYMBOL		

SOLUTION TANK ASSEMBLY

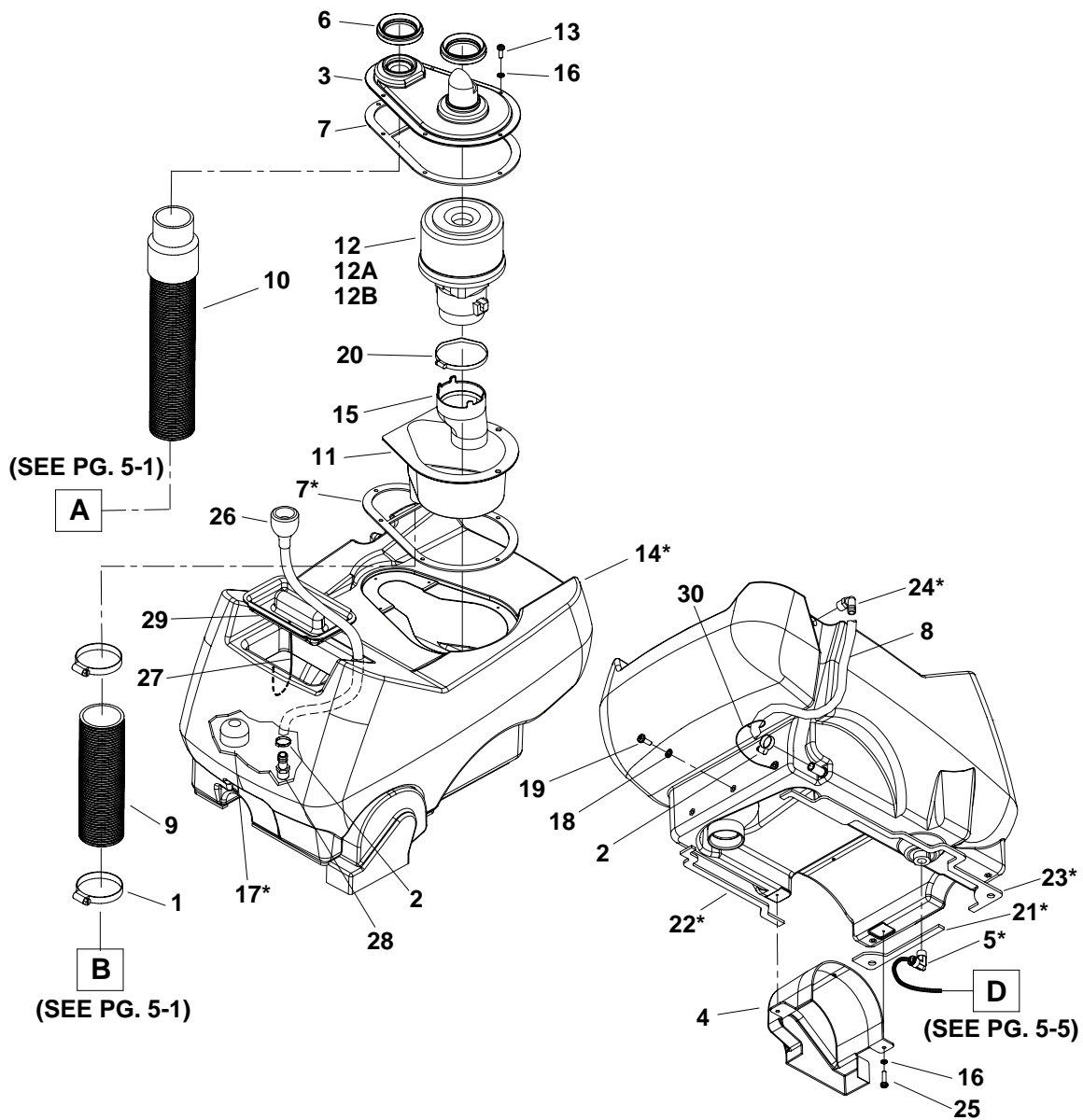

SOLUTION TANK ASSEMBLY

REF	PART NO.	PRV NO.	QTY	DESCRIPTION	SERIAL NO. FROM	NOTES:
1	86233140	20041	2	CLAMP, 2.0" WORM GEAR		
2	86233150	20042	2	CLAMP, 3/8 HOSE (D-SLOT)		
3	86003080	27809	1	COVER, VAC MOTOR		
4	86003090	27810	1	COVER, BELT		
5	86235500	31081	1	ELBOW, 3/8 MPT X 3/8 TUBE, PLASTIC		
6	86003790	35175	2	GASKET, TANK TO VAC COVER		
7	86003920	35231	2	GASKET, VAC COVER (CLP FAMILY)		
8	86281880	39526	1	HOSE, 1/2 CLEAR X 12		
9	86240100	39536	1	HOSE, 1.5 BLK VAC X 5.0		
10	86004340	39528	REF	HOSE ASM, 1.5 BLK VAC X 15.5		
11	86161450	41348	1	HOUSING, VAC MOTOR		
12	86026880	53789	1	VAC MOTOR ASM, CLP FAMILY		
12A	86135340	14258		BRUSH SET, 120V 5.7 VAC, AMETEK	*	SERVICE ONLY
12B	86135320	140687		BRUSH SET, 120V VAC, WINDSOR	*	SERVICE ONLY
13	86275690	70525	6	SCR, #10 X 1.0 PPHST TYPE B		
14	86032280	75261	1	TANK, CLP SOLUTION		
15	86259070	85038	1	VENT, COOLING AIR LARGE		
16	86010650	87018	8	WASHER, #10 X 9/16 OD		
17	86007970	73864	1	STRAINER, 3/8 IN. NPT 60 MESH		
18	86010630	87013	3	WASHER, 1/4 ID X 5/8 OD SS		
19	86006580	70085	3	SCR, 1/4-20 X 1/2 PPHMS SS DL		
20	86079260	20092	1	CLAMP, 3.5" WORM GEAR		
21	86003950	35236	1	GASKET, TANK, L-F		
22	86003960	35237	1	GASKET, TANK, L-R		
23	86003970	35238	1	GASKET, TANK, RH		
24	86068510	40027	1	HOSEBARB, 3/8MPTX1/2 90D DL		
25	86202590	70114	2	SCR, #10 X 3/4 PPHST TYPE B		
26	86260690	02130	1	HOSE ASSY- FILL HOSE		
27	86002870	27417	1	CORD, 99807 1/8 X 12"		
28	86114100	40023	1	HOSEBARB, 1/2MPT X 3/8 DL		
29	86234790	27827	1	COVER, CLP SOLUTION		
30	86246060	51321	1	LANYARD, .06 X 2.88		
31	86026680	75278	1	TANK ASM, SOLUTION CLP12		*ITEMS INCLUDED

RECOVERY TANK ASSEMBLY

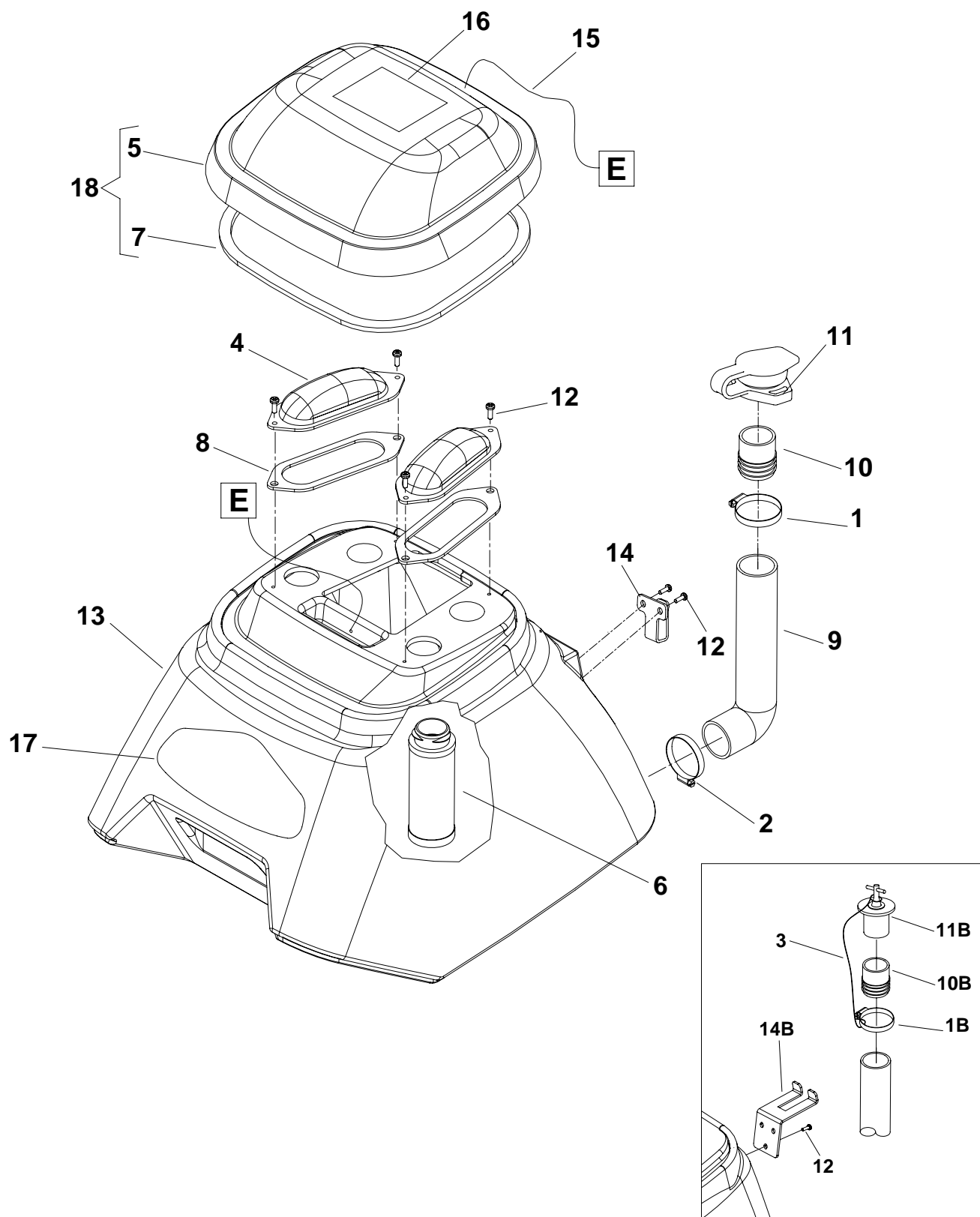

RECOVERY TANK ASSEMBLY

REF	PART NO.	PRV NO.	QTY	DESCRIPTION	SERIAL NO. FROM	NOTES:
1A	86002400	20064	1	CLAMP, 2.0" WORM GEAR X .312	1000083387	
1B	86078220	20002	1	CLAMP, 2.0" NYLON RATCHET		
2	86233140	20041	1	CLAMP, 2.0" WORM GEAR		
3	86002930	27670	1	CORD, DRAIN PLUG		
4	86003110	27816	2	COVER, REC. TANK		
5	86115280	28060	1	DOME, CLP FAMILY		
6	86003630	34351	1	FLOAT SHUT-OFF		
7	86003910	35230	1	GASKET, DOME		
8	86003930	35232	2	GASKET, PORT COVER		
9	86004200	39353	1	HOSE, 1.5 X 12.0 DRAIN		
10A	86004510	41391	1	HOSE, INSERT	1000083387	
10B	86068490	40019	1	HOSEBARB, 1.50 DOUBLE MCHD		
11A	86004500	41390	1	HOSE, CAP	1000083387	
11B	86006240	66227	1	PLUG, DRAIN HOSE		
12	86006600	70114	6	SCR, #10 X 3/4 PPHST TYPE B		
13	86032290	75262	1	TANK, CLP RECOVERY		
14A	86001370	140408	1	BRKT, HOSE HOOK	1000083387	
14B	86001190	140133	1	BRKT, RECOVERY HOSE MTG		
15	86002870	27417	1	CORD, 99807 1/8 X 12"		
16	86242230	500009	1	LABEL, WARNING		
17	86245920	50993	1	LABEL, CLIPPER MAIN		
18	86003330	28061	1	DOME ASM, CLP FAM		

SUGGESTED SPARE PARTS

PART NO.	PRV NO.	DESCRIPTION	SERIAL # FROM	NOTES:
86001150	12515	BRUSH, 18L X 3.38OD		WAS 12032
86001100	11045	BELT, 180J6 MICRO-V		
86000090	09019	BEARING, 1.125ODX.500IDX.375		
86004570	44067	JET BODY, MINI PROMAX BODY		
86004580	44068	JET, MINI PROMAX 9504		
86025730	65201	PUMP ASM, CLP/ADM		
86026940	84160	VALVE ASM, SOLENOID CLP FAMILY		
86003780	35171	GASKET, ACCESSORY PORT		
86001980	14700	BREAKER, 15A 250VAC 50VDC		
86230210	14832	BREAKER, 6A VDE CIRCUIT		
86007140	72130	SWITCH, SPST 2-POSITION ROCKER		
86007200	72162	SWITCH, DPDT3-POSITION ROCKER		
86026880	53789	VAC MOTOR ASM, CLP FAMILY		
86007970	73864	STRAINER, 3/8 IN. NPT 60 MESH		
86003330	28061	DOME ASM, CLP FAMILY		
86003630	34351	FLOAT SHUT-OFF		
86006240	66227	PLUG, DRAIN HOSE		
86135340	14258	BRUSH SET, 120V 5.7 VAC, AMETEK		*
86135320	140687	BRUSH SET, 120V VAC, WINDSOR		*